



BEAMS & COLUMNS

ASTM (AMERICAN)

- W Shapes (W)

SULB

- W Shapes (SOLAR)
- Universal Beams (UB)
- Universal Columns (UC)

AS / NZS (AUSTRALIAN / NEW ZEALAND)

- Universal Beams (UB)
- Universal Columns (UC)

EN (EUROPEAN)

- Universal Beams (UB)
- Universal Columns (UC)
- Parallel Flange I-Beams (IPE)
- Wide Flange H-Beams (HE)

IS (INDIAN)

- NPB Parallel Flange Beams (Narrow Flange) (NPB)
- Parallel Flange Beams (Wide Flange) (WPB)

JIS (JAPANESE)

- H-Beams

KS (KOREAN)

- H-Beams





ASTM W-Shapes

W shapes in accordance with ASTM A6/A6M

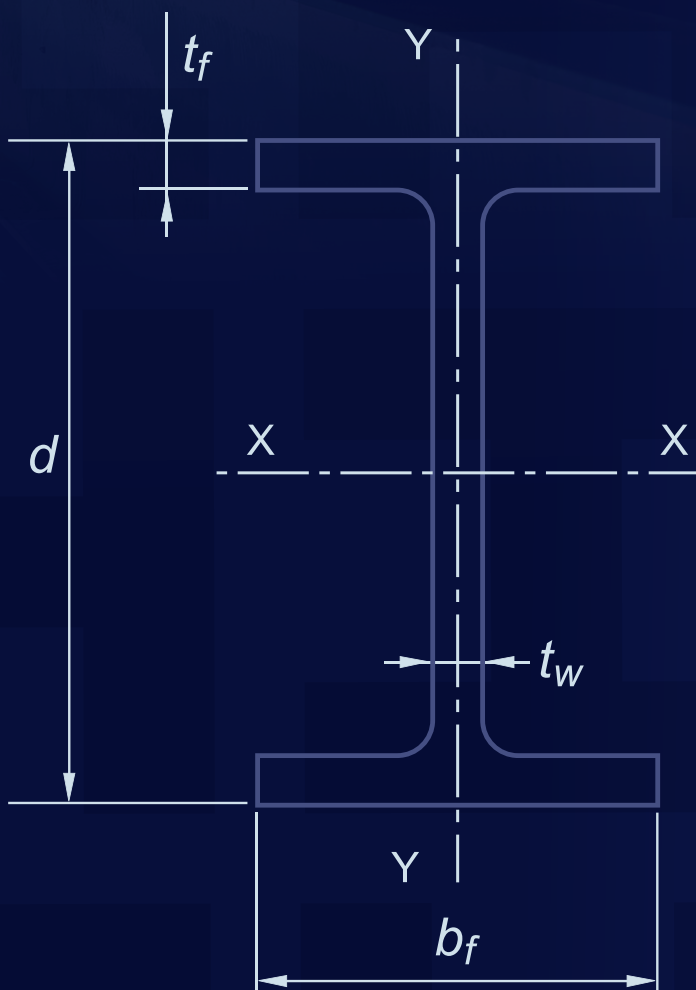



ASTM W-Shapes

Saudi SULB Range = **
Camber Tolerance as per EN 10034 = ‡

ASTM A6 Standard Section Dimensions (Imperial)					
W Shape Designation <small>(Nominal Depth in Inches and Weight in Pounds per Linear Foot)</small>	Area A in ²	Depth d in.	Flange		Web Thickness t _w in.
			Width b _f in.	Thickness t _f in.	
W6 – 6x4 (Imperial) **					
W6x8.5 ‡	2.52	5.83	3.940	0.195	0.170
W6x9 ‡	2.68	5.90	3.940	0.215	0.170
W6x12 ‡	3.55	6.03	4.000	0.280	0.230
W6x16 ‡	4.74	6.28	4.030	0.405	0.260
W6 – 6x6 (Imperial)					
W6x15	4.43	5.99	5.990	0.260	0.230
W6x20	5.87	6.20	6.020	0.365	0.260
W6x25	7.34	6.38	6.080	0.455	0.320
W8 – 8x4 (Imperial) **					
W8x13 ‡	3.84	7.99	4.000	0.255	0.230
W8x15 ‡	4.44	8.11	4.015	0.315	0.245
W8 – 8x5¼ (Imperial)					
W8x18	5.26	8.14	5.250	0.330	0.230
W8x21	6.16	8.28	5.270	0.400	0.250
W8 – 8x6½ (Imperial)					
W8x24	7.08	7.93	6.495	0.400	0.245
W8x28	8.25	8.06	6.535	0.465	0.285
W8 – 8x8 (Imperial)					
W8x31	9.13	8.00	7.995	0.435	0.285
W8x35	10.3	8.12	8.020	0.495	0.310
W8x40	11.7	8.25	8.070	0.560	0.360
W8x48	14.1	8.50	8.110	0.685	0.400
W8x58	17.1	8.75	8.220	0.810	0.510
W8x67	19.7	9.00	8.280	0.935	0.570
W10 – 10x4 (Imperial)					
W10x12	3.54	9.87	3.960	0.210	0.190
W10x15	4.41	9.99	4.000	0.270	0.230
W10x17	4.99	10.11	4.010	0.330	0.240
W10x19	5.62	10.24	4.020	0.395	0.250
W10 – 10x5¼ (Imperial)					
W10x22	6.49	10.17	5.750	0.360	0.240
W10x26	7.61	10.33	5.770	0.440	0.260
W10x30	8.84	10.47	5.810	0.510	0.300
W10 – 10x8 (Imperial)					
W10x33	9.71	9.73	7.960	0.435	0.290
W10x39	11.5	9.92	7.985	0.530	0.315
W10x45	13.3	10.10	8.020	0.620	0.350
W10 – 10x10 (Imperial)					
W10x49	14.4	9.98	10.000	0.560	0.340
W10x54	15.8	10.09	10.030	0.615	0.370
W10x60	17.6	10.22	10.080	0.680	0.420
W10x68	20.0	10.40	10.130	0.770	0.470
W10x77	22.6	10.60	10.190	0.870	0.530
W10x88	25.9	10.84	10.265	0.990	0.605
W10x100	29.4	11.10	10.340	1.120	0.680
W10x112	32.9	11.36	10.415	1.250	0.755
W12 – 12x4 (Imperial)					
W12x14	4.16	11.91	3.970	0.225	0.200
W12x16	4.71	11.99	3.990	0.265	0.220
W12x19	5.57	12.16	4.005	0.350	0.235
W12x22	6.48	12.31	4.030	0.425	0.260
W12 – 12x6½ (Imperial)					
W12x26	7.65	12.22	6.490	0.380	0.230
W12x30	8.79	12.34	6.520	0.440	0.260
W12x35	10.3	12.50	6.560	0.520	0.300

ASTM A6M Standard Section Dimensions (Metric)					
W Shape Designation <small>(Nominal Depth in Millimetres and Mass in Kilograms per Metre)</small>	Area A mm ²	Depth d mm	Flange		Web Thickness t _w mm
			Width b _f mm	Thickness t _f mm	
W150 – 150x100 (Metric) **					
W150x13.0 ‡	1,630	148	100	4.9	4.3
W150x13.5 ‡	1,730	150	100	5.5	4.3
W150x18.0 ‡	2,290	153	102	7.1	5.8
W150x24.0 ‡	3,060	160	102	10.3	6.6
W150 – 150x150 (Metric)					
W150x22.5	2,860	152	152	6.6	5.8
W150x29.8	3,790	157	153	9.3	6.6
W150x37.1	4,740	162	154	11.6	8.1
W200 – 200x100 (Metric) **					
W200x19.3 ‡	2,490	203	102	6.5	5.8
W200x22.5 ‡	2,860	206	102	8.0	6.2
W200 – 200x135 (Metric)					
W200x26.6	3,390	207	133	8.4	5.8
W200x31.3	3,970	210	134	10.2	6.4
W200 – 200x160 (Metric)					
W200x35.9	4,570	201	165	10.2	6.2
W200x41.7	5,320	205	166	11.8	7.2
W200 – 200x200 (Metric)					
W200x46.1	5,890	203	203	11.0	7.2
W200x52	6,650	206	204	12.6	7.9
W200x59	7,550	210	205	14.2	9.1
W200x71	9,100	216	206	17.4	10.2
W200x86	11,000	222	209	20.6	13.0
W200x100	12,700	229	210	23.7	14.5
W250 – 250x100 (Metric)					
W250x17.9	2,280	251	101	5.3	4.8
W250x22.3	2,850	254	102	6.9	5.8
W250x25.3	3,220	257	102	8.4	6.1
W250x28.4	3,630	260	102	10.0	6.4
W250 – 250x145 (Metric)					
W250x32.7	4,190	258	146	9.1	6.1
W250x38.5	4,910	262	147	11.2	6.6
W250x44.8	5,700	266	148	13.0	7.6
W250 – 250x200 (Metric)					
W250x49.1	6,260	247	202	11.0	7.4
W250x58	7,420	252	203	13.5	8.0
W250x67	8,580	257	204	15.7	8.9
W250 – 250x250 (Metric)					
W250x73	9,290	253	254	14.2	8.6
W250x80	10,200	256	255	15.6	9.4
W250x89	11,400	260	256	17.3	10.7
W250x101	12,900	264	257	19.6	11.9
W250x115	14,600	269	259	22.1	13.5
W250x131	16,700	275	261	25.1	15.4
W250x149	19,000	282	263	28.4	17.3
W250x167	21,200	289	265	31.8	19.2
W310 – 310x100 (Metric)					
W310x21.0	2,680	303	101	5.7	5.1
W310x23.8	3,040	305	101	6.7	5.6
W310x28.3	3,590	309	102	8.9	6.0
W310x32.7	4,180	313	102	10.8	6.6
W310 – 310x160 (Metric)					
W310x38.7	4,940	310	165	9.7	5.8
W310x44.5	5,670	313	166	11.2	6.6
W310x52	6,650	317	167	13.2	7.6



ASTM W-Shapes

Saudi SULB Range = **
Camber Tolerance as per EN 10034 = ‡

ASTM A6 Standard Section Dimensions (Imperial)					
W Shape Designation (Nominal Depth in Inches and Weight in Pounds per Linear Foot)	Area A in ²	Depth d in.	Flange		Web Thickness t _w in.
			Width b _f in.	Thickness t _f in.	
W12 – 12x8 (Imperial)					
W12x40	11.8	11.94	8.005	0.515	0.295
W12x45	13.2	12.06	8.045	0.575	0.335
W12x50	14.7	12.19	8.080	0.640	0.370
W12 – 12x10 (Imperial)					
W12x53	15.6	12.06	9.995	0.575	0.345
W12x58	17.0	12.19	10.010	0.640	0.360
W12 – 12x12 (Imperial)					
W12x65	19.1	12.12	12.000	0.605	0.390
W12x72	21.1	12.25	10.040	0.670	0.430
W12x79	23.2	12.38	12.080	0.735	0.470
W12x87	25.6	12.53	12.125	0.810	0.515
W12x96	28.2	12.71	12.160	0.900	0.550
W12x106	31.2	12.89	12.220	0.990	0.610
W12x120	35.3	13.12	12.320	1.105	0.710
W12x136	39.9	13.41	12.400	1.250	0.790
W12x152	44.7	13.71	12.480	1.400	0.870
W12x170	50.0	14.03	12.570	1.560	0.960
W12x190	55.8	14.38	12.670	1.735	1.060
W12x210	61.8	14.71	12.790	1.900	1.180
W12x230	67.7	15.05	12.895	2.070	1.285
W14 – 14x5 (Imperial)					
W14x22	6.49	13.74	5.000	0.335	0.230
W14x26	7.69	13.91	5.025	0.420	0.255
W14 – 14x6¾ (Imperial)					
W14x30	8.85	13.84	6.730	0.385	0.270
W14x34	10.0	13.98	6.745	0.455	0.285
W14x38	11.2	14.10	6.770	0.515	0.310
W14 – 14x8 (Imperial)					
W14x43	12.6	13.66	7.995	0.530	0.305
W14x48	14.1	13.79	8.030	0.595	0.340
W14x53	15.6	13.92	8.060	0.660	0.370
W14 – 14x10 (Imperial)					
W14x61	17.9	13.89	9.995	0.645	0.375
W14x68	20.0	14.04	10.035	0.720	0.415
W14x74	21.8	14.17	10.070	0.785	0.450
W14x82	24.1	14.31	10.130	0.855	0.510
W14 – 14x14½ (Imperial)					
W14x90	26.5	14.02	14.520	0.710	0.440
W14x99	29.1	14.16	14.565	0.780	0.485
W14x109	32.0	14.32	14.605	0.860	0.525
W14x120	35.3	14.48	14.670	0.940	0.590
W14x132	38.8	14.66	14.725	1.030	0.645
W14 – 14x16 (Imperial)					
W14x145	42.7	14.78	15.500	1.090	0.680
W14x159	46.7	14.98	15.565	1.190	0.745
W14x176	51.8	15.22	15.650	1.310	0.830
W14x193	56.8	15.48	15.710	1.440	0.890
W16 – 16x5½ (Imperial)					
W16x26	7.68	15.69	5.500	0.345	0.250
W16x31	9.12	15.88	5.525	0.440	0.275

ASTM A6M Standard Section Dimensions (Metric)					
W Shape Designation (Nominal Depth in Millimetres and Mass in Kilograms per Metre)	Area A mm ²	Depth d mm	Flange		Web Thickness t _w mm
			Width b _f mm	Thickness t _f mm	
W310 – 310x200 (Metric)					
W310x60	7,610	303	203	13.1	7.5
W310x67	8,520	306	204	14.6	8.5
W310x74	9,480	310	205	16.3	9.4
W310 – 310x250 (Metric)					
W310x79	10,100	306	254	14.6	8.8
W310x86	11,000	310	254	16.3	9.1
W310 – 310x310 (Metric)					
W310x97	12,300	308	305	15.4	9.9
W310x107	13,600	311	306	17.0	10.9
W310x117	15,000	314	307	18.7	11.9
W310x129	16,500	318	308	20.6	13.1
W310x143	18,200	323	309	22.9	14.0
W310x158	20,100	327	310	25.1	15.5
W310x179	22,800	333	313	28.1	18.0
W310x202	25,700	341	315	31.8	20.1
W310x226	28,800	348	317	35.6	22.1
W310x253	32,300	356	319	39.6	24.4
W310x283	36,000	365	322	44.1	26.9
W310x313	39,900	374	325	48.3	30.0
W310x342	43,700	382	328	52.6	32.6
W360 – 360x130 (Metric)					
W360x32.9	4,190	349	127	8.5	5.8
W360x39.0	4,960	353	128	10.7	6.5
W360 – 360x170 (Metric)					
W360x44.6	5,710	352	171	9.8	6.9
W360x51	6,450	355	171	11.6	7.2
W360x58	7,230	358	172	13.1	7.9
W360 – 360x200 (Metric)					
W360x64	8,130	347	203	13.5	7.7
W360x72	9,100	350	204	15.1	8.6
W360x79	10,100	354	205	16.8	9.4
W360 – 360x250 (Metric)					
W360x91	11,500	353	254	16.4	9.5
W360x101	12,900	357	255	18.3	10.5
W360x110	14,100	360	256	19.9	11.4
W360x122	15,500	363	257	21.7	13.0
W360 – 360x370 (Metric)					
W360x134	17,100	356	369	18.0	11.2
W360x147	18,800	360	370	19.8	12.3
W360x162	20,600	364	371	21.8	13.3
W360x179	22,800	368	373	23.9	15.0
W360x196	25,000	372	374	26.2	16.4
W360 – 360x410 (Metric)					
W360x216	27,500	375	394	27.7	17.3
W360x237	30,100	380	395	30.2	18.9
W360x262	33,400	387	398	33.3	21.1
W360x287	36,600	393	399	36.6	22.6
W410 – 410x140 (Metric)					
W410x38.8	4,950	399	140	8.8	6.4
W410x46.1	5,880	403	140	11.2	7.0



ASTM W-Shapes

Saudi SULB Range = **
Camber Tolerance as per EN 10034 = ‡

ASTM A6 Standard Section Dimensions (Imperial)					
W Shape Designation <small>(Nominal Depth in Inches and Weight in Pounds per Linear Foot)</small>	Area A in ²	Depth d in.	Flange		Web Thickness t _w in.
			Width b _f in.	Thickness t _f in.	
W16 – 16x7 (Imperial)					
W16x36	10.6	15.86	6.985	0.430	0.295
W16x40	11.8	16.01	6.995	0.505	0.305
W16x45	13.3	16.13	7.035	0.565	0.345
W16x50	14.7	16.26	7.070	0.630	0.380
W16x57	16.8	16.43	7.120	0.715	0.430
W16 – 16x10¼ (Imperial)					
W16x67	19.7	16.33	10.235	0.665	0.395
W16x77	22.6	16.52	10.295	0.760	0.455
W16x89	26.2	16.75	10.365	0.875	0.525
W16x100	29.4	16.97	10.425	0.985	0.585
W18 – 18x6 (Imperial)					
W18x35	10.3	17.70	6.000	0.425	0.300
W18x40	11.8	17.90	6.015	0.525	0.315
W18x46	13.5	18.06	6.060	0.605	0.360
W18 – 18x7½ (Imperial)					
W18x50	14.7	17.99	7.495	0.570	0.355
W18x55	16.2	18.11	7.530	0.630	0.390
W18x60	17.6	18.24	7.555	0.695	0.415
W18x65	19.1	18.35	7.590	0.750	0.450
W18x71	20.8	18.47	7.635	0.810	0.495
W18 – 18x11 (Imperial)					
W18x76	22.3	18.21	11.035	0.680	0.425
W18x86	25.3	18.39	11.090	0.770	0.480
W18x97	28.5	18.59	11.145	0.870	0.535
W18x106	31.1	18.73	11.200	0.940	0.590
W18x119	35.1	18.97	11.265	1.060	0.655
W18x130	38.2	19.25	11.160	1.200	0.670
W18x143	42.1	19.49	11.220	1.320	0.730
W18x158	46.3	19.72	11.300	1.440	0.810
W18x175	51.3	20.04	11.375	1.590	0.890
W18x192	56.4	20.35	11.455	1.750	0.960
W21 – 21x6½ (Imperial)					
W21x44	13.0	20.66	6.500	0.450	0.350
W21x50	14.7	20.83	6.530	0.535	0.380
W21x57	16.7	21.06	6.555	0.650	0.405
W21 – 21x8¼ (Imperial)					
W21x48	14.1	20.62	8.140	0.430	0.350
W21x55	16.2	20.80	8.220	0.522	0.375
W21x62	18.3	20.99	8.240	0.615	0.400
W21x68	20.0	21.13	8.270	0.685	0.430
W21x73	21.5	21.24	8.295	0.740	0.455
W21x83	24.3	21.43	8.355	0.835	0.515
W21x93	27.3	21.62	8.420	0.930	0.580
W21 – 21x12¼ (Imperial)					
W21x101	29.8	21.36	12.290	0.800	0.500
W21x111	32.7	21.51	12.340	0.875	0.550
W21x122	35.9	21.68	12.390	0.960	0.600
W24 – 24x7 (Imperial)					
W24x55	16.2	23.57	7.005	0.505	0.395
W24x62	18.2	23.74	7.040	0.590	0.430

ASTM A6M Standard Section Dimensions (Metric)					
W Shape Designation <small>(Nominal Depth in Millimetres and Mass in Kilograms per Metre)</small>	Area A mm ²	Depth d mm	Flange		Web Thickness t _w mm
			Width b _f mm	Thickness t _f mm	
W410 – 410x180 (Metric)					
W410x53	6,840	403	177	10.9	7.5
W410x60	7,610	407	178	12.8	7.7
W410x67	8,580	410	179	14.4	8.8
W410x75	9,480	413	180	16.0	9.7
W410x85	10,800	417	181	18.2	10.9
W410 – 410x260 (Metric)					
W410x100	12,700	415	260	16.9	10.0
W410x114	14,600	420	261	19.3	11.6
W410x132	16,900	425	263	22.2	13.3
W410x149	19,000	431	265	25.0	14.9
W460 – 460x150 (Metric)					
W460x52	6,650	450	152	10.8	7.6
W460x60	7,610	455	153	13.3	8.0
W460x68	8,710	459	154	15.4	9.1
W460 – 460x190 (Metric)					
W460x74	9,480	457	190	14.5	9.0
W460x82	10,500	460	191	16.0	9.9
W460x89	11,400	463	192	17.7	10.5
W460x97	12,300	466	193	19.0	11.4
W460x106	13,400	469	194	20.6	12.6
W460 – 460x280 (Metric)					
W460x113	14,400	463	280	17.3	10.8
W460x128	16,300	467	282	19.6	12.2
W460x144	18,400	472	283	22.1	13.6
W460x158	20,100	476	284	23.9	15.0
W460x177	22,600	482	286	26.9	16.6
W460x193	24,700	489	283	30.5	17.0
W460x213	27,100	495	285	33.5	18.5
W460x235	29,900	501	287	36.6	20.6
W460x260	33,100	509	289	40.4	22.6
W460x286	36,400	517	291	44.4	24.4
W530 – 530x165 (Metric)					
W530x66	8,390	525	165	11.4	8.9
W530x74	9,480	529	166	13.6	9.7
W530x85	10,800	535	166	16.5	10.3
W530 – 530x210 (Metric)					
W530x72	9,180	524	207	10.9	9.0
W530x82	10,500	528	209	13.3	9.50
W530x92	11,800	533	209	15.6	10.2
W530x101	12,900	537	210	17.4	10.9
W530x109	13,900	539	211	18.8	11.6
W530x123	15,700	544	212	21.2	13.1
W530x138	17,600	549	214	23.6	14.7
W530 – 530x310 (Metric)					
W530x150	19,200	543	312	20.3	12.7
W530x165	21,100	546	313	22.2	14.0
W530x182	23,200	551	315	24.4	15.2
W610 – 610x180 (Metric)					
W610x82	10,500	599	178	12.8	10.0
W610x92	11,700	603	179	15.0	10.9



ASTM W-Shapes

Saudi SULB Range = **
Camber Tolerance as per EN 10034 = ‡

ASTM A6 Standard Section Dimensions (Imperial)					
W Shape Designation <small>(Nominal Depth in Inches and Weight in Pounds per Linear Foot)</small>	Area A in ²	Depth d in.	Flange		Web Thickness t _w in.
			Width b _f in.	Thickness t _f in.	
W24 – 24x9 (Imperial)					
W24x68	20.1	23.73	8.965	0.585	0.415
W24x76	22.4	23.92	8.990	0.680	0.440
W24x84	24.7	24.10	9.020	0.770	0.470
W24x94	27.7	24.31	9.065	0.875	0.515
W24x103	30.3	24.53	9.000	0.980	0.590
W24 – 24x12¾ (Imperial)					
W24x104	30.6	24.06	12.750	0.750	0.500
W24x117	34.4	24.26	12.800	0.850	0.550
W24x131	38.5	24.48	12.885	0.960	0.605
W27 – 27x10 (Imperial)					
W27x84	24.8	26.71	9.960	0.640	0.460
W27x94	27.7	26.92	9.990	0.745	0.490
W27x102	30.0	27.09	10.015	0.830	0.515
W27x114	33.5	27.29	10.070	0.930	0.570
W27x129	37.8	27.63	10.010	1.100	0.610
W30 – 30x10½ (Imperial)					
W30x90	26.4	29.53	10.400	0.610	0.470
W30x99	29.1	29.65	10.450	0.670	0.520
W30x108	31.7	29.83	10.475	0.760	0.545
W30x116	34.2	30.01	10.495	0.850	0.565
W30x124	36.5	30.17	10.515	0.930	0.585
W30x132	38.9	30.31	10.545	1.000	0.615
W30x148	43.5	30.67	10.480	1.180	0.650
W33 – 33x11½ (Imperial)					
W33x118	34.7	32.86	11.480	0.740	0.550
W33x130	38.3	33.09	11.510	0.855	0.580
W33x141	41.6	33.30	11.535	0.960	0.605
W33x152	44.7	33.49	11.565	1.055	0.635
W33x169	49.5	33.82	11.500	1.220	0.670
W36 – 36x12 (Imperial)					
W36x135	39.7	35.55	11.950	0.790	0.600
W36x150	44.2	35.85	11.975	0.940	0.625
W36x160	47.0	36.01	12.000	1.020	0.650
W36x170	50.0	36.17	12.030	1.100	0.680
W36x182	53.6	36.33	12.075	1.180	0.725
W36x194	57.0	36.49	12.115	1.260	0.765
W36x210	61.8	36.69	12.180	1.360	0.830

ASTM A6M Standard Section Dimensions (Metric)					
W Shape Designation <small>(Nominal Depth in Millimetres and Mass in Kilograms per Metre)</small>	Area A mm ²	Depth d mm	Flange		Web Thickness t _w mm
			Width b _f mm	Thickness t _f mm	
W610 – 610x230 (Metric)					
W610x101	13,000	603	228	14.9	10.5
W610x113	14,500	608	228	17.3	11.2
W610x125	15,900	612	229	19.6	11.9
W610x140	17,900	617	230	22.2	13.1
W610x153	19,600	623	229	24.9	14.0
W610 – 610x324 (Metric)					
W610x155	19,700	611	324	19.0	12.7
W610x174	22,200	616	325	21.6	14.0
W610x195	24,800	622	327	24.4	15.4
W690 – 690x250 (Metric)					
W690x125	16,000	678	253	16.3	11.7
W690x140	17,900	684	254	18.9	12.4
W690x152	19,400	688	254	21.1	13.1
W690x170	21,600	693	256	23.6	14.5
W690x192	24,400	702	254	27.9	15.5
W760 – 760x270 (Metric)					
W760x134	17,000	750	264	15.5	11.9
W760x147	18,800	753	265	17.0	13.2
W760x161	20,500	758	266	19.3	13.8
W760x173	22,100	762	267	21.6	14.4
W760x185	23,500	766	267	23.6	14.9
W760x196	25,100	770	268	25.4	15.6
W760x220	28,100	779	266	30.0	16.5
W840 – 840x290 (Metric)					
W840x176	22,400	835	292	18.8	14.0
W840x193	24,700	840	292	21.7	14.7
W840x210	26,800	846	293	24.4	15.4
W840x226	28,800	851	294	26.8	16.1
W840x251	31,900	859	292	31.0	17.0
W920 – 920x310 (Metric)					
W920x201	25,600	903	304	20.1	15.2
W920x223	28,500	911	304	23.9	15.9
W920x238	30,300	915	305	25.9	16.5
W920x253	32,300	919	306	27.9	17.3
W920x271	34,600	923	307	30.0	18.4
W920x289	36,800	927	308	32.0	19.4
W920x313	39,900	932	309	34.5	21.1



SULB W-Shapes (Solar)

W shapes in accordance with SULB Standard.

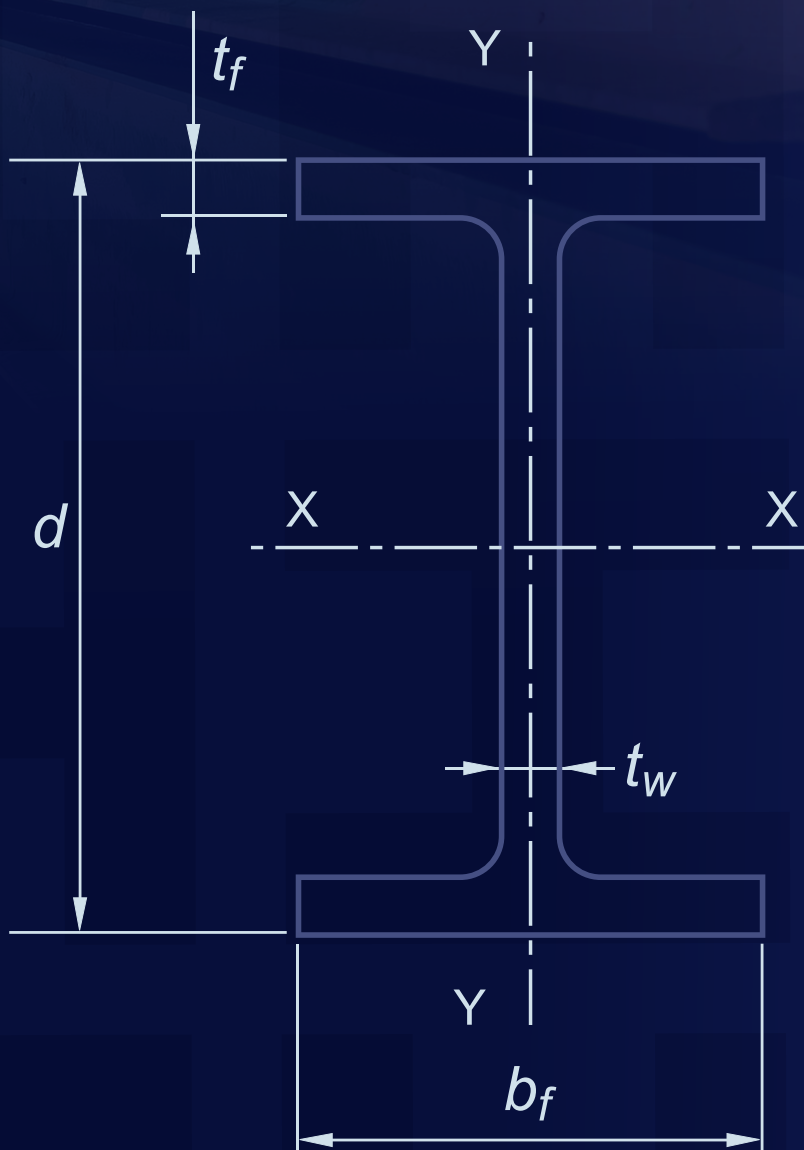



SULB W-Shapes (Solar)

* = Dimensions and Tolerances
as per SULB Standard 'SOLAR'
Technical Delivery Conditions
(TDC) - available upon request.

SULB 'Solar' Section Dimensions (Imperial)					
W Shape Designation (Nominal Depth in Inches and Weight in Pounds per Linear Foot)	Area A in ²	Depth d in.	Flange		Web Thickness t _w in.
			Width b _f in.	Thickness t _f in.	
W6 - 6x4 (Imperial)					
W6x7 *	2.10	5.77	3.94	0.165	0.129
W6x8 *	2.37	5.83	3.940	0.185	0.157
W8 - 8x4 (Imperial)					
W8x10 *	2.96	7.89	3.940	0.205	0.170

SULB 'Solar' Section Dimensions (Metric)					
W Shape Designation (Nominal Depth in Millimetres and Mass in Kilograms per Metre)	Area A mm ²	Depth d mm	Flange		Web Thickness t _w mm
			Width b _f mm	Thickness t _f mm	
W150 - 150x100 (Metric)					
W150x10.5 *	1,350	147	100	4.2	3.3
W150x12.2 *	1,530	148	100	4.7	4.0
W200 - 200x100 (Metric)					
W200x15.0 *	1,910	200	100	5.2	4.3



SULB Universal Beams (UB)

Dimensions and Masses in accordance with SULB Standard. Tolerances in accordance with EN 10034. Surface Condition in accordance with EN 10163-3, class C, subclass 1.

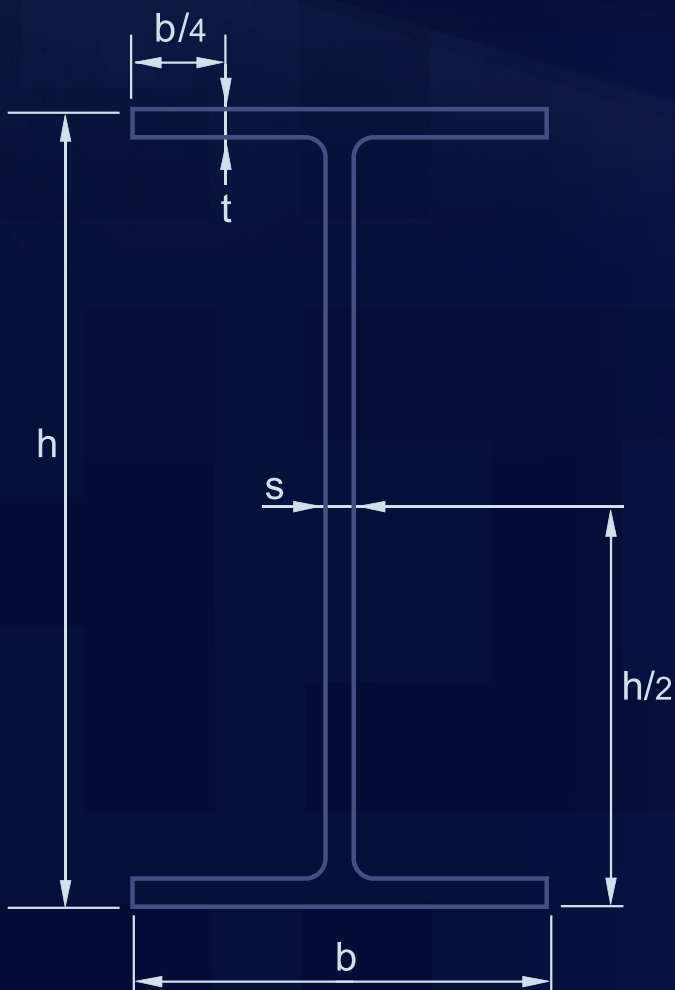



SULB Universal Beams (UB)

Bahrain Rolling Mill ●
Saudi Arabia Rolling Mill ●

Designation	G kg/m	Dimensions				A cm ²	
		h mm	b mm	s mm	t mm		
UB 254 x 102 x 18	17,9	251,0	101,0	4,8	5,3	23,1	●
UB 305 x 102 x 21	21,0	303,0	101,0	5,1	5,7	27,2	●
UB 305 x 102 x 24	24,0	305,0	101,0	5,6	6,7	30,7	●
UB 406 x 178 x 85	85,3	417,2	181,9	10,9	18,2	109,0	●
UB 457 x 280 x 113	113,0	463,0	280,0	10,8	17,3	144,0	●
UB 457 x 280 x 128	128,0	467,0	282,0	12,2	19,6	163,0	●
UB 457 x 280 x 144	144,0	472,0	283,0	13,6	22,1	184,0	●
UB 457 x 280 x 158	158,0	476,0	284,0	15,0	23,9	201,0	●
UB 457 x 280 x 177	177,0	482,0	286,0	16,6	26,9	226,0	●
UB 457 x 280 x 193	193,0	489,0	283,0	17,0	30,5	247,0	●
UB 457 x 280 x 213	213,0	495,0	285,0	18,5	33,5	271,0	●
UB 457 x 280 x 235	235,0	501,0	287,0	20,6	36,6	299,0	●
UB 457 x 280 x 260	260,0	509,0	289,0	22,6	40,4	331,0	●
UB 457 x 280 x 286	286,0	517,0	291,0	24,4	44,4	364,0	●
UB 457 x 191 x 106	105,8	469,2	194,0	12,6	20,6	135,1	●
UB 533 x 165 x 66	66,0	525,0	165,0	8,9	11,4	83,9	●
UB 533 x 165 x 74	74,0	529,0	166,0	9,7	13,6	94,8	●
UB 533 x 165 x 85	85,0	535,0	166,0	10,3	16,5	108,0	●
UB 533 x 210 x 72	72,0	524,0	207,0	9,0	10,9	91,8	●
UB 533 x 210 x 138	138,3	549,1	213,9	14,7	23,6	176,2	●
UB 533 x 312 x 150	150,0	542,5	312	12,7	20,3	191,9	●
UB 533 x 312 x 165	165,0	546,0	313,0	14,0	22,2	210,6	●
UB 533 x 312 x 182	181,5	550,7	314,5	15,2	24,4	231,2	●
UB 610 x 178 x 82	81,5	598,6	177,9	10,0	12,8	104,3	●
UB 610 x 178 x 92	92,0	603,0	178,0	10,9	15,0	127,4	●
UB 610 x 229 x 153	153,0	623,0	229,0	14,0	24,9	195,7	●
UB 610 x 324 x 155	155,0	611,0	324,0	12,7	19,0	197,0	●
UB 610 x 324 x 174	174,0	616,0	325,0	14,0	21,6	222,0	●
UB 610 x 324 x 195	195,0	622,0	327,0	15,4	24,4	248,0	●
UB 686 x 254 x 192	192,0	702,0	254,0	15,5	27,9	243,8	●
UB 762 x 267 x 161	161,0	758,0	266,0	13,8	19,3	204,4	●
UB 762 x 267 x 185	185,0	766,0	267,0	14,9	23,6	235,6	●
UB 762 x 267 x 220	220,0	779,0	266,0	16,5	30,0	280,7	●
UB 838 x 292 x 210	210,0	846,0	293,0	15,4	24,4	268,5	●
UB 838 x 292 x 251	251,0	859,0	292,0	17,0	31,0	319,3	●



SULB Universal Columns (UC)

Dimensions and Masses in accordance with SULB Standard. Tolerances in accordance with EN 10034. Surface Condition in accordance with EN 10163-3, class C, subclass 1.

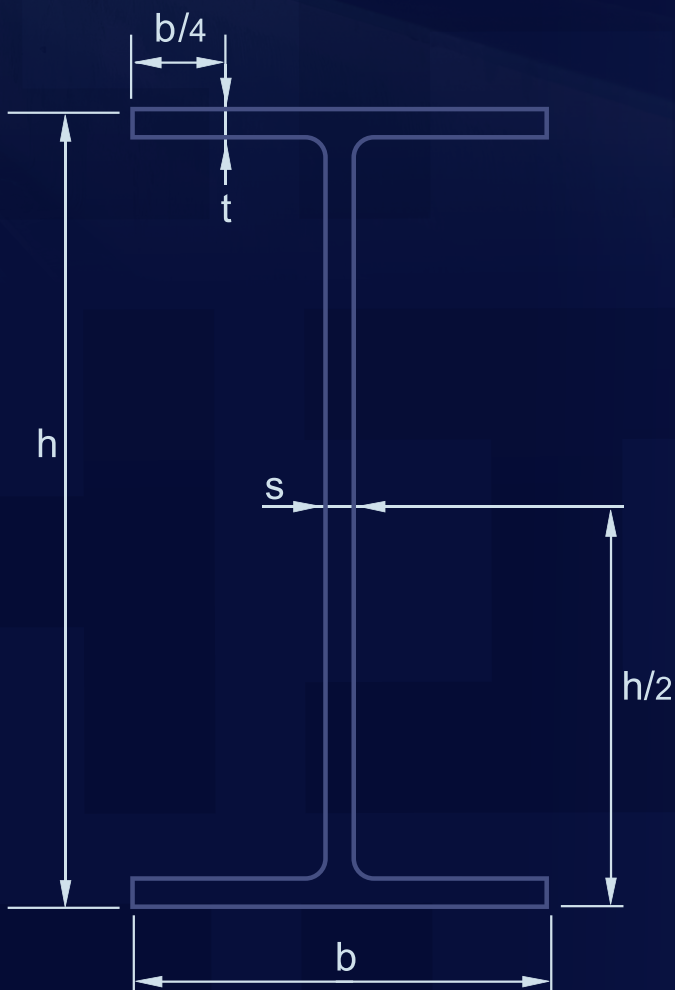



SULB Universal Columns (UC)

Bahrain Rolling Mill ●
Saudi Arabia Rolling Mill ●

Designation	G kg/m	Dimensions				A cm ²	
		h mm	b mm	s mm	t mm		
UC 203 x 203 x 100	99,6	228,6	210,3	14,5	23,7	127,2	●
UC 254 x 254 x 81	81,0	256,0	255,0	9,4	15,6	102,6	●
UC 254 x 254 x 101	101,0	264,0	257,0	11,9	19,6	129,4	●
UC 254 x 254 x 115	115,0	269,0	259,0	13,5	22,1	146,8	●
UC 254 x 254 x 149	149,0	282,0	263,0	17,3	28,4	190,3	●
UC 305 x 305 x 107	107,0	311,0	306,0	10,9	17,0	136,2	●
UC 305 x 305 x 129	129,0	318,0	308,0	13,1	20,6	165,1	●
UC 305 x 305 x 143	143,0	323,0	309,0	14,0	22,9	182,3	●
UC 305 x 305 x 179	179,0	333,0	313,0	18,0	28,1	227,1	●
UC 305 x 305 x 202	202,0	341,0	315,0	20,1	31,8	258,0	●
UC 305 x 305 x 226	226,0	348,0	317,0	22,1	35,6	288,8	●
UC 305 x 305 x 253	253,0	356,0	319,0	24,4	39,6	322,1	●
UC 305 x 305 x 313	313,0	374,0	325,0	30,0	48,3	399,1	●
UC 305 x 305 x 342	342,0	382,0	328,0	32,6	52,6	437,2	●
UC 356 x 368 x 134	134,0	356,0	369,0	11,2	18,0	171,0	●
UC 356 x 368 x 147	147,0	360,0	370,0	12,3	19,8	188,0	●
UC 356 x 368 x 162	162,0	364,0	371,0	13,3	21,8	206,0	●
UC 356 x 368 x 179	179,0	368,0	373,0	15,0	23,9	228,0	●
UC 356 x 368 x 199	199,0	372,0	374,0	16,4	26,2	171,0	●
UC 356 x 406 x 216	216,0	375,0	394,0	17,3	27,7	275,5	●
UC 356 x 406 x 237	237,0	380,0	395,0	18,9	30,2	300,9	●
UC 356 x 406 x 262	262,0	387,0	398,0	21,1	33,3	334,6	●



AS/NZS Universal Beams (UB)

Dimensions, Masses, Tolerances and Surface Condition in accordance with AS/NZS 3679.1

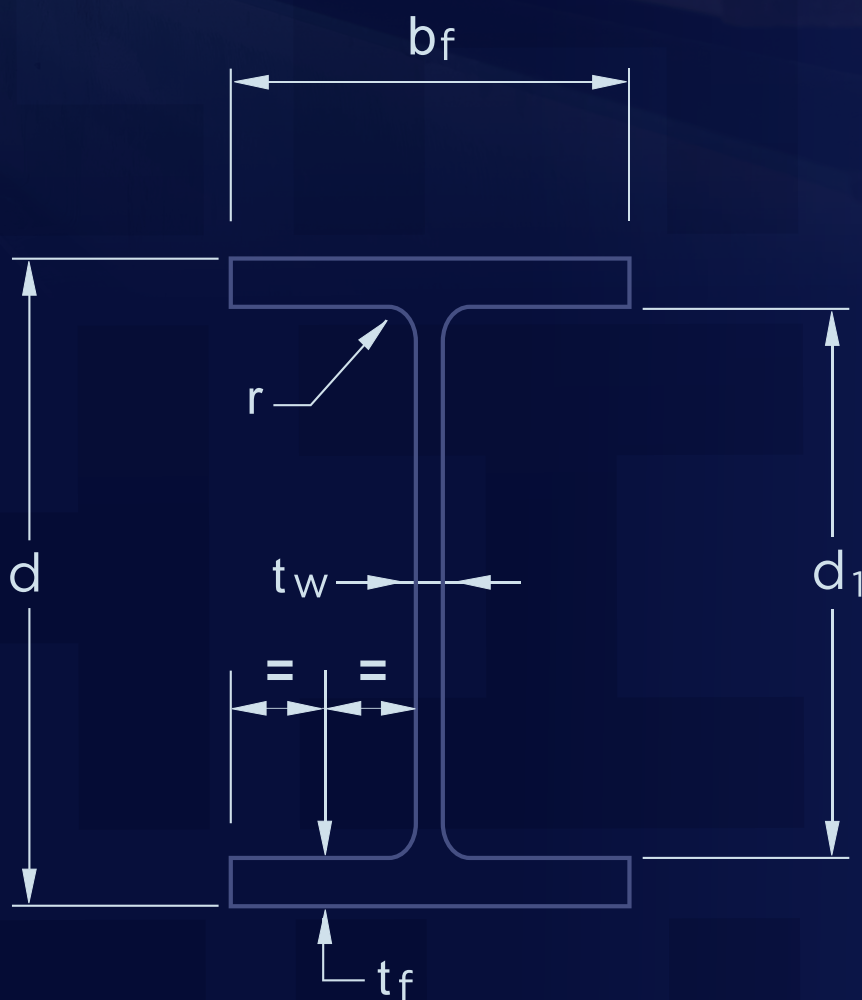



AS/NZS Universal Beams (UB)

Bahrain Rolling Mill ●
Saudi Arabia Rolling Mill ●

Designation	Dimensions							
	kg/m	Depth of Section (d) mm	Flange		Web Thickness (tw) mm	Root Radius (r) mm	Depth Between Flanges (d1) mm	
			Width (bf) mm	Thickness (tf) mm				
200 UB	22,3	201,6	133,0	7,0	5,0	8,9	187,6	●
	25,4	203,2	133,0	7,8	5,8	8,9	187,6	●
	29,8	207,0	134,0	9,6	6,3	8,9	187,6	●
250 UB	25,7	248,0	124,0	8,0	5,0	12,0	232,0	●
		31,4	251,6	146,0	8,6	6,1	8,9	●
		37,3	256,2	146,0	10,9	6,4	8,9	●
310 UB	32,0	298,0	149,0	8,0	5,5	11,4	282,0	●
		40,4	304,0	165,0	10,2	6,1	11,4	●
		46,2	307,2	166,0	11,8	6,7	11,4	●
360 UB	44,7	352,0	171,0	9,7	6,9	11,4	332,6	●
		50,7	355,6	171,0	11,5	7,3	11,4	●
		56,7	358,6	172,0	13,0	8,0	11,4	●
410 UB	53,7	402,6	178,0	10,9	7,6	11,4	380,8	●
		59,7	406,4	178,0	12,8	7,8	11,4	●
460 UB	67,1	453,8	190,0	12,7	8,5	11,4	428,8	●
		74,6	457,4	190,0	14,5	9,1	11,4	●
		82,1	460,4	191,0	16,1	9,9	11,4	●
530 UB	82,0	528,2	209,0	13,2	9,6	14,0	501,8	●
		92,4	533,0	209,0	15,6	10,2	14,0	●
610 UB	101	602,0	228,0	14,8	10,6	14,0	572,4	●
		113	607,0	228,0	17,3	11,2	14,0	●
		125	611,6	229,0	19,6	11,9	14,0	●



AS/NZS Universal Columns (UC)

Dimensions, Masses, Tolerances and Surface Condition in accordance with AS/NZS 3679.1

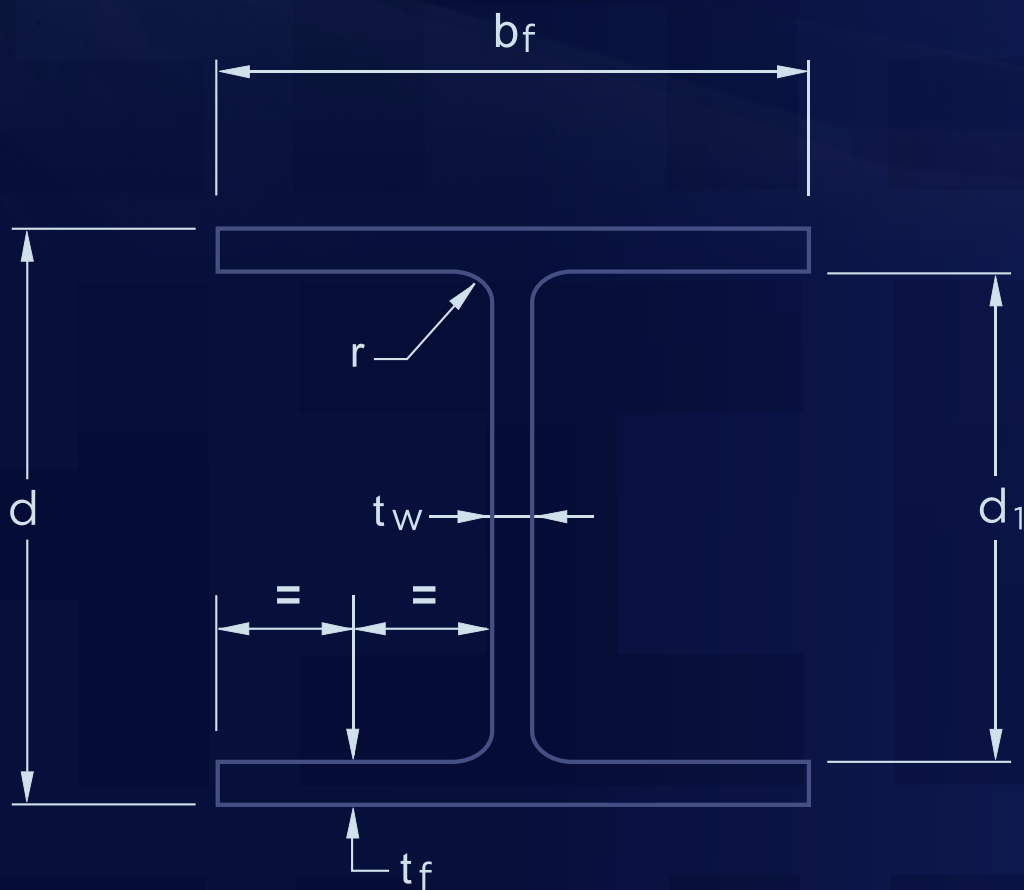



AS/NZS Universal Columns (UC)

Bahrain Rolling Mill ●
Saudi Arabia Rolling Mill ●

Designation	Dimensions							
	kg/m	Depth of Section (d) mm	Flange		Web Thickness (tw) mm	Root Radius (r) mm	Depth Between Flanges (d1) mm	
			Width (bf) mm	Thickness (tf) mm				
150 UC	23,4	152,4	152,0	6,8	6,1	8,9	138,8	●
	30,0	157,6	153,0	9,4	6,6	8,9	138,8	●
	37,2	161,8	154,0	11,5	8,1	8,9	138,8	●
200 UC	46,2	203,4	203,0	11,0	7,3	11,4	181,4	●
		52,2	206,4	204,0	12,5	8,0	11,4	●
		59,5	209,8	205,0	14,2	9,3	11,4	●
250 UC	72,9	253,8	254,0	14,2	8,6	14,0	225,4	●
		89,5	260,0	256,0	17,3	10,5	14,0	●
310 UC	96,8	308,0	305,0	15,4	9,9	16,5	277,2	●
		118	314,6	307,0	18,7	11,9	16,5	●
		137	320,6	309,0	21,7	13,8	16,5	●
		158	327,2	311,0	25,0	15,7	16,5	●



EN Universal Beams (UB)

Dimensions and Masses in accordance with EN 10365 (Previously BS 4-1). Tolerances in accordance with EN 10034. Surface Condition in accordance with EN 10163-3, class C, subclass 1.

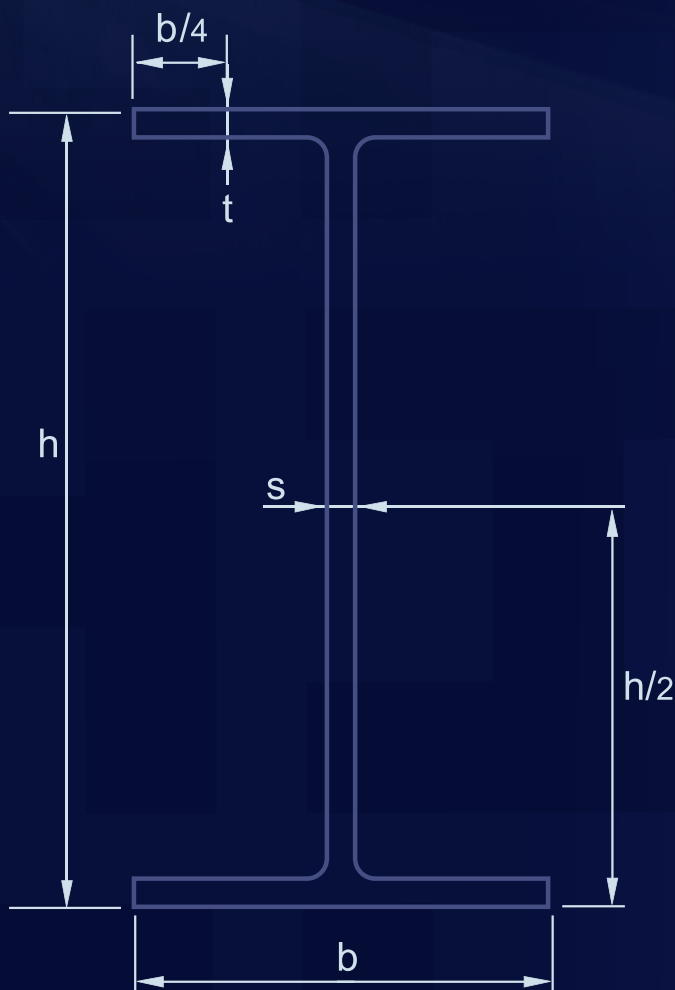



EN Universal Beams (UB)

Bahrain Rolling Mill ●
 Saudi Arabia Rolling Mill ●
 Subject to mill confirmation *

Designation	G kg/m	Dimensions				A cm ²	
		h mm	b mm	s mm	t mm		
UB 203 x 102 x 23	23,1	203,2	101,8	5,4	9,3	29,4	●
UB 203 x 133 x 25	25,1	203,2	133,2	5,7	7,8	32,0	●
UB 203 x 133 x 30	30,0	206,8	133,9	6,4	9,6	38,2	●
UB 254 x 102 x 22	22,0	254,0	101,6	5,7	6,8	28,0	●
UB 254 x 102 x 25	25,2	257,2	101,9	6,0	8,4	32,0	●
UB 254 x 102 x 28	28,3	260,4	102,2	6,3	10,0	36,1	●
UB 254 x 146 x 31	31,1	251,4	146,1	6,0	8,6	39,7	●
UB 254 x 146 x 37	37,0	256,0	146,4	6,3	10,9	47,2	●
UB 254 x 146 x 43	43,0	259,6	147,3	7,2	12,7	54,8	●
UB 305 x 102 x 25	24,8	305,1	101,6	5,8	7,0	31,6	●
UB 305 x 102 x 28	28,2	308,7	101,8	6,0	8,8	35,9	●
UB 305 x 102 x 33	32,8	312,7	102,4	6,6	10,8	41,8	●
UB 305 x 127 x 37	37,0	304,4	123,4	7,1	10,7	47,2	●
UB 305 x 127 x 42	41,9	307,2	124,3	8,0	12,1	53,4	●
UB 305 x 127 x 48	48,1	311,0	125,3	9,0	14,0	61,2	●
UB 305 x 165 x 40	40,3	303,4	165,0	6,0	10,2	51,3	●
UB 305 x 165 x 46	46,1	306,6	165,7	6,7	11,8	58,7	●
UB 305 x 165 x 54	54,0	310,4	166,9	7,9	13,7	68,8	●
UB 356 x 127 x 33	33,1	349,0	125,4	6,0	8,5	42,1	●
UB 356 x 127 x 39	39,1	353,4	126,0	6,6	10,7	49,8	●
UB 356 x 171 x 45	45,0	351,4	171,1	7,0	9,7	57,3	●
UB 356 x 171 x 51	51,0	355,0	171,5	7,4	11,5	64,9	●
UB 356 x 171 x 57	57,0	358,0	172,2	8,1	13,0	72,6	●
UB 356 x 171 x 67	67,1	363,4	173,2	9,1	15,7	85,5	●
UB 406 x 140 x 39	39,0	398,0	141,8	6,4	8,6	49,7	●
UB 406 x 140 x 46	46,0	403,2	142,2	6,8	11,2	58,6	●
UB 406 x 178 x 54	54,1	402,6	177,7	7,7	10,9	69,0	●
UB 406 x 178 x 60	60,1	406,4	177,9	7,9	12,8	76,5	●
UB 406 x 178 x 67	67,1	409,4	178,8	8,8	14,3	85,5	●
UB 406 x 178 x 74	74,2	412,8	179,5	9,5	16,0	94,5	●
UB 457 x 152 x 52	52,3	449,8	152,4	7,6	10,9	66,6	●
UB 457 x 152 x 60	59,8	454,6	152,9	8,1	13,3	76,2	●
UB 457 x 152 x 67	67,2	458,0	153,8	9,0	15,0	85,6	●
UB 457 x 152 x 74	74,2	462,0	154,4	9,6	17,0	94,5	●
UB 457 x 152 x 82	82,1	465,8	155,3	10,5	18,9	104,5	●
UB 457 x 191 x 67	67,1	453,4	189,9	8,5	12,7	85,5	●
UB 457 x 191 x 74	74,3	457,0	190,4	9,0	14,5	94,6	●
UB 457 x 191 x 82	82,0	460,0	191,3	9,9	16,0	104,5	●
UB 457 x 191 x 89	89,3	463,4	191,9	10,5	17,7	113,8	●
UB 457 x 191 x 98	98,3	467,2	192,8	11,4	19,6	125,3	●
UB 533 x 210 x 82	82,2	528,3	208,8	9,6	13,2	104,7	●
UB 533 x 210 x 92	92,1	533,1	209,3	10,1	15,6	117,4	●
UB 533 x 210 x 101	101	536,7	210,0	10,8	17,4	128,7	●
UB 533 x 210 x 109	109	539,5	210,8	11,6	18,8	138,9	●
UB 533 x 210 x 122	122	544,5	211,9	12,7	21,3	155,4	●
UB 610 x 229 x 101	101	602,6	227,6	10,5	14,8	128,9	●
UB 610 x 229 x 113	113	607,6	228,2	11,1	17,3	143,9	●
UB 610 x 229 x 125	125	612,2	229,0	11,9	19,6	159,3	●
UB 610 x 229 x 140	140	617,2	230,2	13,1	22,1	178,2	●



EN Universal Beams (UB)

Bahrain Rolling Mill ●
 Saudi Arabia Rolling Mill ●
 Subject to mill confirmation *

Designation	G kg/m	Dimensions				A cm ²	
		h mm	b mm	s mm	t mm		
UB 610 x 305 x 149	149	612,4	304,8	11,8	19,7	190,0	●
UB 610 x 305 x 179	179	620,2	307,1	14,1	23,6	228,1	●
UB 610 x 305 x 238	238	635,8	311,4	18,4	31,4	303,3	●
UB 686 x 254 x 125	125	677,9	253,0	11,7	16,2	159,5	●
UB 686 x 254 x 140	140	683,5	253,7	12,4	19,0	178,4	●
UB 686 x 254 x 152	152	687,5	254,5	13,2	21,0	194,1	●
UB 686 x 254 x 170	170	692,9	255,8	14,5	23,7	216,8	●
UB 762 x 267 x 134	134	750,0	264,4	12,0	15,5	170,6	●
UB 762 x 267 x 147	147	754,0	265,2	12,8	17,5	187,2	●
UB 762 x 267 x 173	173	762,2	266,7	14,3	21,6	220,4	●
UB 762 x 267 x 197	197	769,8	268,0	15,6	25,4	250,6	●
UB 838 x 292 x 176	176	834,9	291,7	14,0	18,8	224,0	●
UB 838 x 292 x 194	194	840,7	292,4	14,7	21,7	246,8	●
UB 838 x 292 x 226	226	850,9	293,8	16,1	26,8	288,6	●
UB 914 x 305 x 201	201	903,0	303,3	15,1	20,2	255,9	●
UB 914 x 305 x 224	224	910,4	304,1	15,9	23,9	285,6	●
UB 914 x 305 x 238	238	915,0	305,0	16,5	25,9	303,5	●
UB 914 x 305 x 253	253	918,4	305,5	17,3	27,9	322,8	●
UB 914 x 305 x 271	271	923,0	307,0	18,4	30,0	346,1	●
UB 914 x 305 x 289	289	926,6	307,7	19,5	32,0	368,3	●
UB 914 x 305 x 313	313	932,0	309,0	21,1	34,5	398,4	●



EN Universal Columns (UC)

Dimensions and Masses in accordance with EN 10365 (Previously BS 4-1). Tolerances in accordance with EN 10034. Surface Condition in accordance with EN 10163-3, class C, subclass 1.

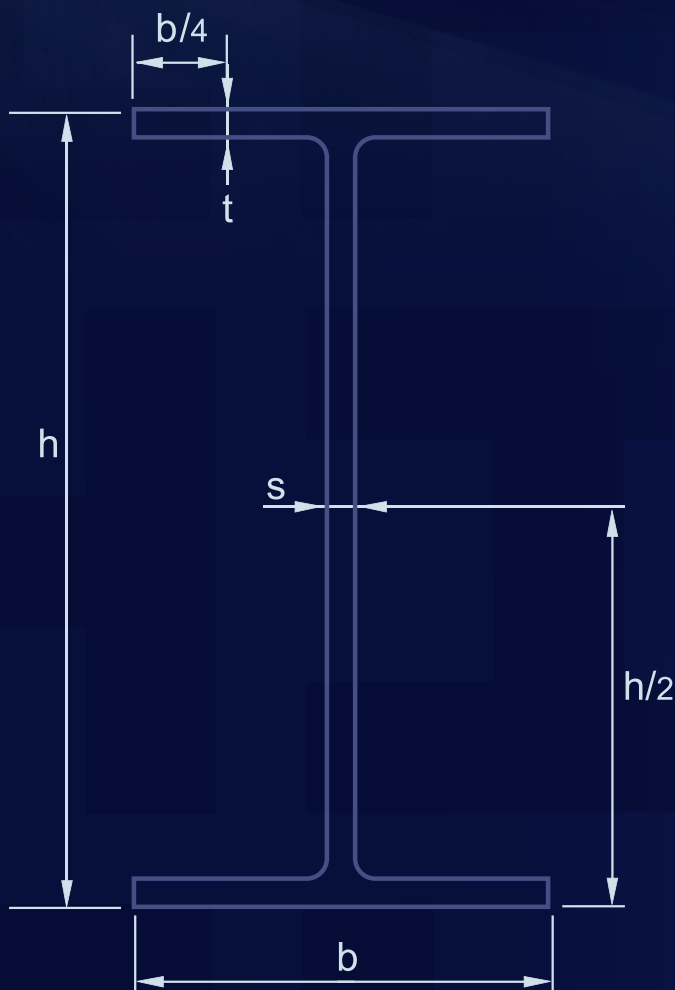



EN Universal Columns (UC)

Bahrain Rolling Mill ●
 Saudi Arabia Rolling Mill ●
 Subject to mill confirmation *

Designation	G kg/m	Dimensions				A cm ²	
		h mm	b mm	s mm	t mm		
UC 152 x 152 x 23	23,0	152,4	152,2	5,8	6,8	29,2	●
UC 152 x 152 x 30	30,0	157,6	152,9	6,5	9,4	38,3	●
UC 152 x 152 x 37	37,0	161,8	154,4	8,0	11,5	47,1	●
UC 203 x 203 x 46	46,1	203,2	203,6	7,2	11,0	58,7	●
UC 203 x 203 x 52	52,0	206,2	204,3	7,9	12,5	66,3	●
UC 203 x 203 x 60	60,0	209,6	205,8	9,4	14,2	76,4	●
UC 203 x 203 x 71	71,0	215,8	206,4	10,0	17,3	90,4	●
UC 203 x 203 x 86	86,1	222,2	209,1	12,7	20,5	109,6	●
UC 254 x 254 x 73	73,1	254,1	254,6	8,6	14,2	93,1	●
UC 254 x 254 x 89	88,9	260,3	256,3	10,3	17,3	113,3	●
UC 254 x 254 x 107	107	266,7	258,8	12,8	20,5	136,4	●
UC 254 x 254 x 132	132	276,3	261,3	15,3	25,3	168,1	●
UC 254 x 254 x 167	167	289,1	265,2	19,2	31,7	212,9	●
UC 305 x 305 x 97	96,9	307,9	305,3	9,9	15,4	123,4	●
UC 305 x 305 x 118	118	314,5	307,4	12,0	18,7	150,2	●
UC 305 x 305 x 137	137	320,5	309,2	13,8	21,7	174,4	●
UC 305 x 305 x 158	158	327,1	311,2	15,8	25,0	201,4	●
UC 305 x 305 x 198	198	339,9	314,5	19,1	31,4	252,4	●
UC 305 x 305 x 240	240	352,5	318,4	23,0	37,7	305,8	●
UC 305 x 305 x 283	283	365,3	322,2	26,8	44,1	360,4	●
UC 356 x 368 x 129	129	355,6	368,6	10,4	17,5	164,3	●
UC 356 x 368 x 153	153	362,0	370,5	12,3	20,7	194,8	●
UC 356 x 368 x 177	177	368,2	372,6	14,4	23,8	225,5	●
UC 356 x 368 x 202	202	374,6	374,7	16,5	27,0	257,2	●
UC 356 x 406 x 235	235	381,0	394,8	18,4	30,2	299,0	●
UC 356 x 406 x 287	287	393,6	399,0	22,6	36,5	365,7	●
UC 356 x 406 x 340	340	406,4	403,0	26,6	42,9	433,0	●
UC 356 x 406 x 393 *	393	419,0	407,0	30,6	49,2	500,6	●



EN Parallel Flange I-Beams (IPE)

Dimensions and Masses in accordance with EN 10365 (previously Euronorm's).
Tolerances in accordance with EN 10034.
Surface Conditions in accordance with EN 10163-3, class C, subclass 1.

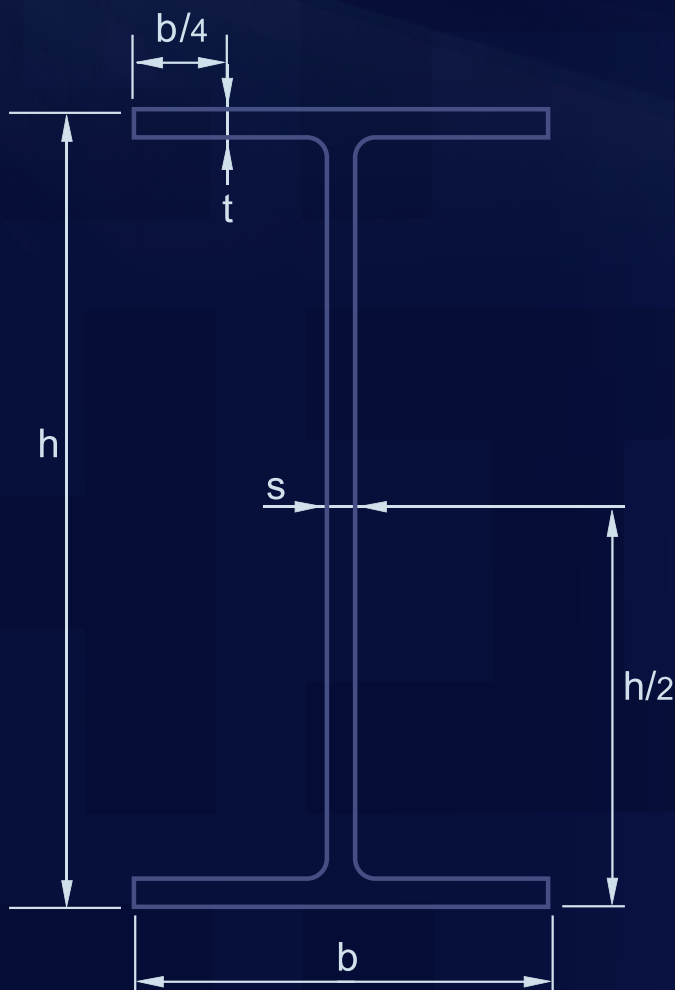



EN Parallel Flange Beams I-Beams (IPE)

Bahrain Rolling Mill ●
Saudi Arabia Rolling Mill ●
Subject to mill confirmation *

Designation	G kg/m	Dimensions				A cm ²	
		h mm	b mm	s mm	t mm		
IPE AA 80	4,9	78,0	46,0	3,2	4,2	6,3	●
IPE A 80	5,0	78,0	46,0	3,3	4,2	6,4	●
IPE 80	6,0	80,0	46,0	3,8	5,2	7,6	●
IPE AA 100	6,7	97,6	55,0	3,6	4,5	8,6	●
IPE A 100	6,9	98,0	55,0	3,6	4,7	8,8	●
IPE 100	8,1	100,0	55,0	4,1	5,7	10,3	●
IPE AA 120	8,4	117,0	64,0	3,8	4,8	10,7	●
IPE A 120	8,7	117,6	64,0	3,8	5,1	11,0	●
IPE 120	10,4	120,0	64,0	4,4	6,3	13,2	●
IPE AA 140	10,1	136,6	73,0	3,8	5,2	12,8	●
IPE A 140	10,5	137,4	73,0	3,8	5,6	13,4	●
IPE 140	12,9	140,0	73,0	4,7	6,9	16,4	●
IPE AA 160	12,3	156,4	82,0	4,0	5,6	15,7	●
IPE A 160	12,7	157,0	82,0	4,0	5,9	16,2	●
IPE 160	15,8	160,0	82,0	5,0	7,4	20,1	●
IPE AA 180	14,9	176,4	91,0	4,3	6,2	19,0	●
IPE A 180	15,4	177,0	91,0	4,3	6,5	19,6	●
IPE 180	18,8	180,0	91,0	5,3	8,0	23,9	●
IPE O 180 *	21,3	182,0	92,0	6,0	9,0	27,1	●
IPE AA 200	18,0	196,4	100,0	4,5	6,7	22,9	●
IPE A 200	18,4	197,0	100,0	4,5	7,0	23,5	●
IPE 200	22,4	200,0	100,0	5,6	8,5	28,5	●
IPE O 200 *	25,1	202,0	102,0	6,2	9,5	32,0	●
IPE AA 220	21,2	216,4	110,0	4,7	7,4	27,0	●
IPE A 220	22,2	217,0	110,0	5,0	7,7	28,3	●
IPE 220	26,2	220,0	110,0	5,9	9,2	33,4	●
IPE O 220 *	29,4	222,0	112,0	6,6	10,2	37,4	●
IPE AA 240 *	24,9	236,4	120,0	4,8	8,0	31,7	●
IPE A 240	26,2	237,0	120,0	5,2	8,3	33,3	●
IPE 240	30,7	240,0	120,0	6,2	9,8	39,1	●
IPE O 240 *	34,3	242,0	122,0	7,0	10,8	43,7	●
IPE A 270	30,7	267,0	135,0	5,5	8,7	39,2	●
IPE 270	36,1	270,0	135,0	6,6	10,2	45,9	●
IPE O 270 *	42,3	274,0	136,0	7,5	12,2	53,8	●
IPE A 300	36,5	297,0	150,0	6,1	9,2	46,5	●
IPE 300	42,2	300,0	150,0	7,1	10,7	53,8	●
IPE O 300 *	49,3	304,0	152,0	8,0	12,7	62,8	●
IPE A 330	43,0	327,0	160,0	6,5	10,0	54,7	●
IPE 330	49,1	330,0	160,0	7,5	11,5	62,6	●
IPE O 330 *	57,0	334,0	162,0	8,5	13,5	72,6	●
IPE A 360	50,2	357,6	170,0	6,6	11,5	64,0	●
IPE 360	57,1	360,0	170,0	8,0	12,7	72,7	●
IPE O 360 *	66,0	364,0	172,0	9,2	14,7	84,1	●
IPE A 400	57,4	397,0	180,0	7,0	12,0	73,1	●
IPE 400	66,3	400,0	180,0	8,6	13,5	84,5	●
IPE O 400	75,7	404,0	182,0	9,7	15,5	96,4	●
IPE V 400 *	84,0	408,8	182,0	10,6	17,5	107,0	●
IPE A 450	67,2	447,0	190,0	7,6	13,1	85,6	●
IPE 450	77,6	450,0	190,0	9,4	14,6	98,8	●
IPE O 450 *	92,4	456,0	192,0	11,0	17,6	117,7	●
IPE V 450 *	107	460,0	194,0	12,4	19,6	132,0	●



EN Parallel Flange Beams I-Beams (IPE)

Bahrain Rolling Mill ●
Saudi Arabia Rolling Mill ●
Subject to mill confirmation *

Designation	G	Dimensions				A	
	kg/m	h mm	b mm	s mm	t mm	cm ²	
IPE A 500	79,4	497,0	200,0	8,4	14,5	101,1	●
IPE 500	90,7	500,0	200,0	10,2	16,0	115,5	●
IPE O 500	107	506,0	202,0	12,0	19,0	136,7	●
IPE V 500 *	129	514,0	204,0	14,2	23,0	164,1	●
IPE A 550	92,1	547,0	210,0	9,0	15,7	117,3	●
IPE 550	106	550,0	210,0	11,1	17,2	134,4	●
IPE O 550 *	123	556,0	212,0	12,7	20,2	156,1	●
IPE V 550 *	159	566,0	216,0	17,1	25,2	202,0	●
IPE A 600	108	597,0	220,0	9,8	17,5	137,0	●
IPE 600	122	600,0	220,0	12,0	19,0	156,0	●
IPE O 600	154	610,0	224,0	15,0	24,0	196,8	●
IPE V 600 *	184	618,0	228,0	18,0	28,0	233,8	●
IPE 750 x 134 *	134	750,0	264,0	12,0	15,5	170,6	●
IPE 750 x 147 *	147	753,0	265,0	13,2	17,0	187,5	●
IPE 750 x 173 *	173	762,0	267,0	14,4	21,6	221,3	●
IPE 750 x 196 *	196	770,0	268,0	15,6	25,4	250,8	●



EN Wide Flange H-Beams (HE)

Dimensions and Masses in accordance with EN 10365 (Previously Euronorm's).
Tolerances in accordance with EN 10034.
Surface Condition in accordance with EN 10163-3, class C, subclass 1.

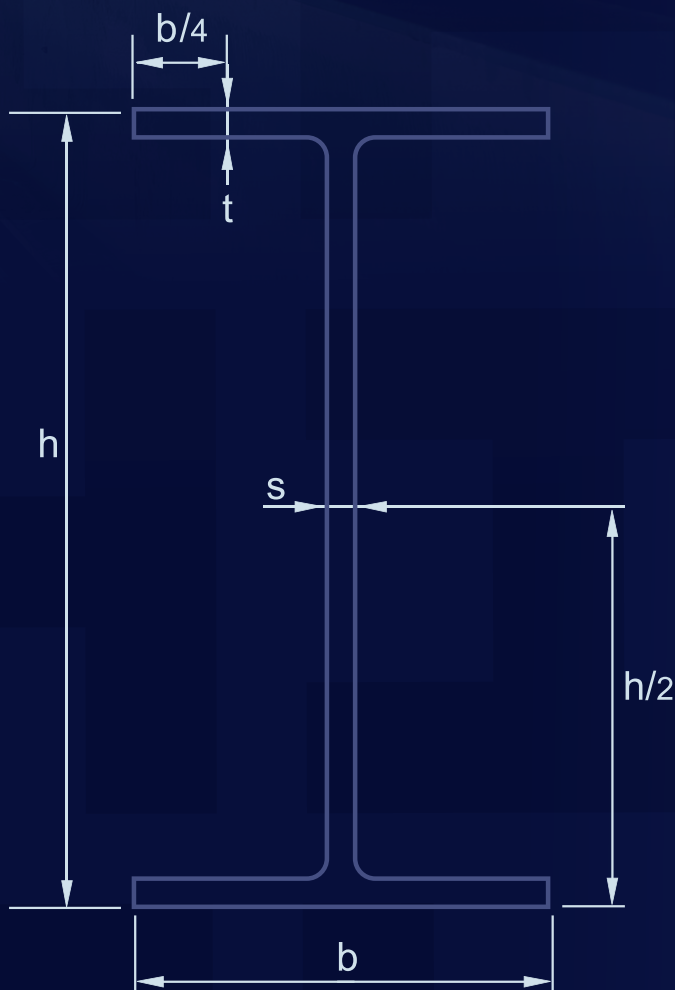



EN Wide Flange Beams H-Beams (HE)

Bahrain Rolling Mill ●
Saudi Arabia Rolling Mill ●
Subject to mill confirmation *

Designation	G kg/m	Dimensions				A cm ²	
		h mm	b mm	s mm	t mm		
HE 100 AA *	12,2	91,0	100,0	4,2	5,5	15,6	●
HE 100 A	16,7	96,0	100,0	5,0	8,0	21,2	●
HE 100 B	20,4	100,0	100,0	6,0	10,0	26,0	●
HE 120 AA *	14,6	109,0	120,0	4,2	5,5	18,6	●
HE 120 A	19,9	114,0	120,0	5,0	8,0	25,3	●
HE 120 B	26,7	120,0	120,0	6,5	11,0	34,0	●
HE 140 AA *	18,1	128,0	140,0	4,3	6,0	23,0	●
HE 140 A	24,7	133,0	140,0	5,5	8,5	31,4	●
HE 140 B	33,7	140,0	140,0	7,0	12,0	43,0	●
HE 140 C	48,2	150,0	143,0	10,0	17,0	61,5	●
HE 140 M	63,2	160,0	146,0	13,0	22,0	80,6	●
HE 160 AA *	23,8	148,0	160,0	4,5	7,0	30,4	●
HE 160 A	30,4	152,0	160,0	6,0	9,0	38,8	●
HE 160 B	42,6	160,0	160,0	8,0	13,0	54,3	●
HE 160 C *	59,2	170,0	163,0	11,0	18,0	75,4	●
HE 160 M	76,2	180,0	166,0	14,0	23,0	97,1	●
HE 180 AA *	28,7	167,0	180,0	5,0	7,5	36,5	●
HE 180 A	35,5	171,0	180,0	6,0	9,5	45,3	●
HE 180 B	51,2	180,0	180,0	8,5	14,0	65,3	●
HE 180 C *	69,8	190,0	183,0	11,5	19,0	89,0	●
HE 180 M	88,9	200,0	186,0	14,5	24,0	113,3	●
HE 200 AA	34,6	186,0	200,0	5,5	8,0	44,1	●
HE 200 A	42,3	190,0	200,0	6,5	10,0	53,8	●
HE 200 B	61,3	200,0	200,0	9,0	15,0	78,1	●
HE 200 C	81,9	210,0	203,0	12,0	20,0	104,4	●
HE 200 M	103	220,0	206,0	15,0	25,0	131,3	●
HE 220 AA	40,4	205,0	220,0	6,0	8,5	51,5	●
HE 220 A	50,5	210,0	220,0	7,0	11,0	64,3	●
HE 220 B	71,5	220,0	220,0	9,5	16,0	91,0	●
HE 220 C *	94,1	230,0	223,0	12,5	21,0	119,9	●
HE 220 M	117	240,0	226,0	15,5	26,0	149,4	●
HE 240 AA	47,4	224,0	240,0	6,5	9,0	60,4	●
HE 240 A	60,3	230,0	240,0	7,5	12,0	76,8	●
HE 240 B	83,2	240,0	240,0	10,0	17,0	106,0	●
HE 240 C *	119	255,0	244,0	14,0	24,5	152,2	●
HE 240 M	157	270,0	248,0	18,0	32,0	199,6	●
HE 260 AA	54,1	244,0	260,0	6,5	9,5	69,0	●
HE 260 A	68,2	250,0	260,0	7,5	12,5	86,8	●
HE 260 B	93,0	260,0	260,0	10,0	17,5	118,4	●
HE 260 C *	132	275,0	264,0	14,0	25,0	168,4	●
HE 260 M	172	290,0	268,0	18,0	32,5	219,6	●
HE 280 AA	61,2	264,0	280,0	7,0	10,0	78,0	●
HE 280 A	76,4	270,0	280,0	8,0	13,0	97,3	●
HE 280 B	103	280,0	280,0	10,5	18,0	131,4	●
HE 280 C *	145	295,0	284,0	14,5	25,5	185,2	●
HE 280 M	189	310,0	288,0	18,5	33,0	240,2	●
HE 300 AA	69,8	283,0	300,0	7,5	10,5	88,9	●
HE 300 A	88,3	290,0	300,0	8,5	14,0	112,5	●
HE 300 B	117	300,0	300,0	11,0	19,0	149,1	●
HE 300 C *	177	320,0	305,0	16,0	29,0	225,1	●
HE 300 M	238	340,0	310,0	21,0	39,0	303,1	●



EN Wide Flange Beams H-Beams (HE)

Bahrain Rolling Mill ●
Saudi Arabia Rolling Mill ●
Subject to mill confirmation *

Designation	G kg/m	Dimensions				A cm ²	
		h mm	b mm	s mm	t mm		
HE 320 AA	74,2	301,0	300,0	8,0	11,0	94,6	●
HE 320 A	97,6	310,0	300,0	9,0	15,5	124,4	●
HE 320 B	127	320,0	300,0	11,5	20,5	161,3	●
HE 320 C *	186	340,0	305,0	16,0	30,5	236,9	●
HE 320 M	245	359,0	309,0	21,0	40,0	312,0	●
HE 340 AA	78,9	320,0	300,0	8,5	11,5	100,5	●
HE 340 A	105	330,0	300,0	9,5	16,5	133,5	●
HE 340 B	134	340,0	300,0	12,0	21,5	170,9	●
HE 340 M	248	377,0	309,0	21,0	40,0	315,8	●
HE 360 AA	83,7	339,0	300,0	9,0	12,0	106,6	●
HE 360 A	112	350,0	300,0	10,0	17,5	142,8	●
HE 360 B	142	360,0	300,0	12,5	22,5	180,6	●
HE 360 M	250	395,0	308,0	21,0	40,0	318,8	●
HE 400 AA	92,4	378,0	300,0	9,5	13,0	117,7	●
HE 400 A	125	390,0	300,0	11,0	19,0	159,0	●
HE 400 B	155	400,0	300,0	13,5	24,0	197,8	●
HE 400 M	256	432,0	307,0	21,0	40,0	325,8	●
HE 450 AA	99,7	425,0	300,0	10,0	13,5	127,1	●
HE 450 A	140	440,0	300,0	11,5	21,0	178,0	●
HE 450 B	171	450,0	300,0	14,0	26,0	218,0	●
HE 450 M	263	478,0	307,0	21,0	40,0	335,4	●
HE 500 AA	107	472,0	300,0	10,5	14,0	136,9	●
HE 500 A	155	490,0	300,0	12,0	23,0	197,5	●
HE 500 B	187	500,0	300,0	14,5	28,0	238,6	●
HE 500 M	270	524,0	306,0	21,0	40,0	344,3	●
HE 550 AA	120	522,0	300,0	11,5	15,0	152,8	●
HE 550 A	166	540,0	300,0	12,5	24,0	211,8	●
HE 550 B	199	550,0	300,0	15,0	29,0	254,1	●
HE 550 M	278	572,0	306,0	21,0	40,0	354,4	●
HE 600 AA	129	571,0	300,0	12,0	15,5	164,1	●
HE 600 A	178	590,0	300,0	13,0	25,0	226,5	●
HE 600 B	212	600,0	300,0	15,5	30,0	270,0	●
HE 600 M	285	620,0	305,0	21,0	40,0	363,7	●
HE 650 AA	138	620,0	300,0	12,5	16,0	175,8	●
HE 650 A	190	640,0	300,0	13,5	26,0	241,6	●
HE 650 B	225	650,0	300,0	16,0	31,0	286,3	●
HE 650 M	293	668,0	305,0	21,0	40,0	373,7	●
HE 700 AA	150	670,0	300,0	13,0	17,0	190,9	●
HE 700 A	204	690,0	300,0	14,5	27,0	260,5	●
HE 700 B	241	700,0	300,0	17,0	32,0	306,4	●
HE 700 M	301	716,0	304,0	21,0	40,0	383,0	●
HE 800 AA	172	770,0	300,0	14,0	18,0	218,5	●
HE 800 A	224	790,0	300,0	15,0	28,0	285,8	●
HE 800 B	262	800,0	300,0	17,5	33,0	334,2	●
HE 800 M	317	814,0	303,0	21,0	40,0	404,3	●
HE 900 AA	198	870,0	300,0	15,0	20,0	252,2	●
HE 900 A	252	890,0	300,0	16,0	30,0	320,5	●
HE 900 B	291	900,0	300,0	18,5	35,0	371,3	●



IS NPB Parallel Flange Beams Narrow Flange

Dimensions and Masses in accordance with IS 12778. Tolerances in accordance with IS 12779.

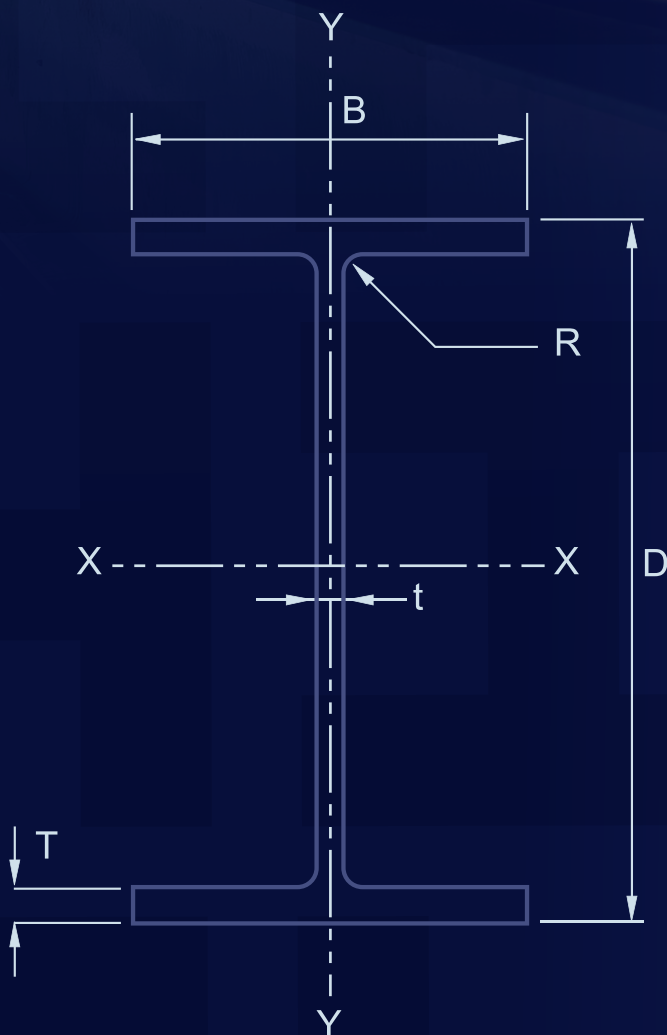



IS NPB Parallel Flange Beams Narrow Flange

Bahrain Rolling Mill ●
Saudi Arabia Rolling Mill ●
Subject to mill confirmation *

Designation	Mass kg/m	Dimensions					A cm ²	
		D Depth - mm	B width - mm	T web - mm	T flange - mm	R radius - mm		
NPB 100 x 55	8,10	100	55	4,1	5,7	7	10,3	●
NPB 120 x 60	10,37	120	64	4,4	6,3	7	13,2	●
NPB 140 x 70	12,89	140	73	4,7	6,9	7	16,4	●
NPB 160 x 80	15,77	160	82	5,0	7,4	9	20,1	●
NPB 180 x 90	15,37	177	91	4,3	6,5	9	19,6	●
NPB 180 x 90	18,80	180	91	5,3	8,0	9	23,9	●
NPB 180 x 90	21,27	182	92	6,0	9,0	9	27,1	●
NPB 200 x 100	18,42	197	100	4,5	7,0	12	23,5	●
NPB 200 x 100	22,36	200	100	5,6	8,5	12	28,5	●
NPB 200 x 100	25,09	202	102	6,2	9,5	12	32,0	●
NPB 220 x 110	22,18	217	110	5,0	7,7	12	28,3	●
NPB 220 x 110	26,20	220	110	5,9	9,2	12	33,4	●
NPB 220 x 110	29,35	222	112	6,6	10,2	12	37,4	●
NPB 240 x 120	26,15	237	120	5,2	8,3	15	33,3	●
NPB 240 x 120	30,71	240	120	6,2	9,8	15	39,1	●
NPB 240 x 120	34,31	242	122	7,0	10,8	15	43,7	●
NPB 270 x 135	30,73	267	135	5,5	8,7	15	39,1	●
NPB 270 x 135	36,07	270	135	6,6	10,2	15	45,9	●
NPB 270 x 135	42,26	274	136	7,5	12,2	15	53,8	●
NPB 300 x 150	36,52	297	150	6,1	9,2	15	46,5	●
NPB 300 x 150	42,24	300	150	7,1	10,7	15	53,8	●
NPB 300 x 150	49,32	304	152	8,0	12,7	15	62,8	●
NPB 330 x 160	42,97	327	160	6,5	10,0	18	54,7	●
NPB 330 x 160	49,15	330	160	7,5	11,5	18	62,6	●
NPB 330 x 160	57,00	334	162	8,5	13,5	18	72,6	●
NPB 350 x 170	50,21	357,6	170	6,6	11,5	18	64,0	●
NPB 350 x 170	57,09	360	170	8,0	12,7	18	72,7	●
NPB 350 x 170	66,04	364	172	9,2	14,7	18	84,1	●
NPB 400 x 180	57,38	397	180	7,0	12,0	21	73,1	●
NPB 400 x 180	66,30	400	180	8,6	13,5	21	84,5	●
NPB 400 x 180	75,66	404	182	9,7	15,5	21	96,4	●
NPB 450 x 190	67,15	447	190	7,6	13,1	21	85,5	●
NPB 450 x 190	77,57	450	190	9,4	14,6	21	98,8	●
NPB 450 x 190	92,36	456	192	11,0	17,6	21	117,7	●
NPB 500 x 200	79,36	497	200	8,4	14,5	21	101,1	●
NPB 500 x 200	90,68	500	200	10,2	16,0	21	115,5	●
NPB 500 x 200	107,31	506	202	12,0	19,0	21	136,7	●
NPB 550 x 210	92,07	547	210	9,0	15,7	24	117,3	●
NPB 550 x 210	105,52	550	210	11,1	17,2	24	134,4	●
NPB 550 x 210	122,52	556	212	12,7	20,2	24	156,1	●
NPB 600 x 220	107,56	597	220	9,8	17,5	24	137,0	●
NPB 600 x 220	122,45	600	220	12,0	19,0	24	156,0	●
NPB 600 x 220	154,46	610	224	15,0	24,0	24	196,8	●



IS WPB Parallel Flange Beams Wide Flange

Dimensions and Masses in accordance with IS 12778. Tolerances in accordance with IS 12779.

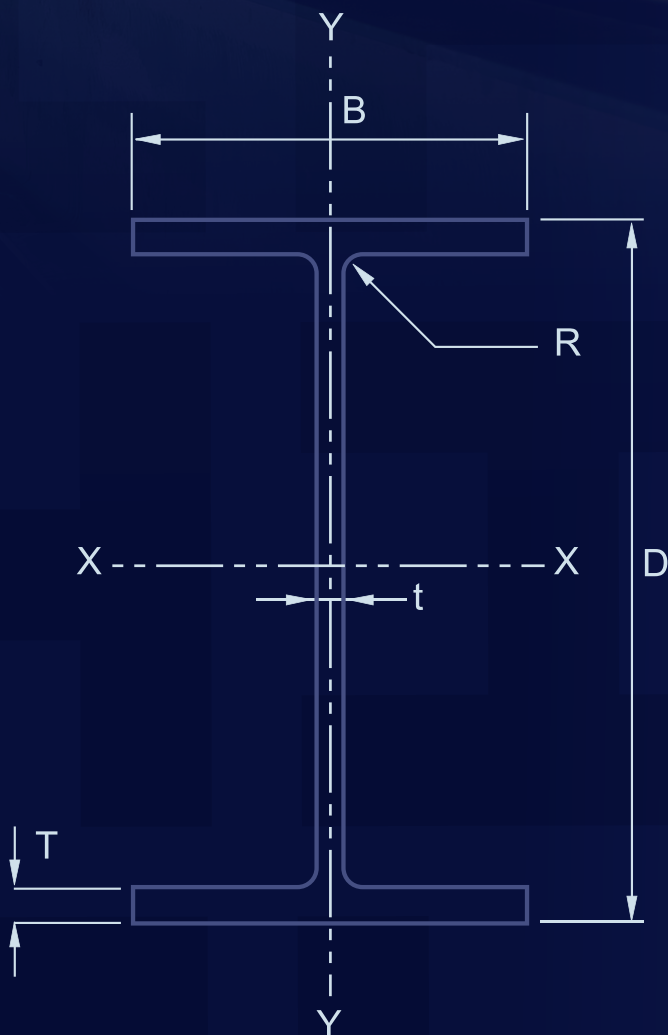



IS WPB Parallel Flange Beams Wide Flange

Bahrain Rolling Mill ●
 Saudi Arabia Rolling Mill ●
 Subject to mill confirmation *

Designation	Mass kg/m	Dimensions					A cm ²	
		D Depth - mm	B width - mm	T web - mm	T flange - mm	R radius - mm		
WPB 100 x 100	12,24	91	100	4,2	5,5	12	15,6	●
WPB 100 x 100	16,67	96	100	5,0	8,0	12	21,2	●
WPB 100 x 100	20,44	100	100	6,0	10,0	12	26,0	●
WPB 120 x 120	14,56	109	120	4,2	5,5	12	18,6	●
WPB 120 x 120	19,89	114	120	5,0	8,0	12	25,3	●
WPB 120 x 120	26,69	120	120	6,5	11,0	12	34,0	●
WPB 160 x 160	23,83	148	160	4,5	7,0	15	30,4	●
WPB 160 x 160	30,44	152	160	6,0	9,0	15	38,8	●
WPB 160 x 160	42,59	160	160	8,0	13,0	15	54,3	●
WPB 160 x 160	76,19	180	166	14,0	23,0	15	97,1	●
WPB 180 x 180	28,68	167	180	5,0	7,5	15	36,5	●
WPB 180 x 180	35,52	171	180	6,0	9,5	15	45,3	●
WPB 180 x 180	51,22	180	180	8,5	14,0	15	65,3	●
WPB 180 x 180	88,90	200	186	14,5	24,0	15	113,3	●
WPB 200 x 200	34,64	186	200	5,5	8,0	18	44,1	●
WPB 200 x 200	42,26	190	200	6,5	10,0	18	53,8	●
WPB 200 x 200	61,29	200	200	9,0	15,0	18	78,1	●
WPB 200 x 200	103,06	220	206	15,0	25,0	18	131,1	●
WPB 220 x 220	40,40	205	220	6,0	8,5	18	51,5	●
WPB 220 x 220	50,51	210	220	7,0	11,0	18	64,3	●
WPB 220 x 220	71,47	220	220	9,5	16,0	18	91,0	●
WPB 220 x 220	117,31	240	226	15,5	26,0	18	149,4	●
WPB 240 x 240	47,39	224	240	6,5	9,0	21	60,4	●
WPB 240 x 240	60,32	230	240	7,5	12,0	21	76,8	●
WPB 240 x 240	83,20	240	240	10,0	17,0	21	106,0	●
WPB 240 x 240	156,67	270	248	18,0	32,0	21	199,6	●
WPB 260 x 260	54,14	244	260	6,5	9,5	24	69,0	●
WPB 260 x 260	68,15	250	260	7,5	12,5	24	86,8	●
WPB 260 x 260	92,98	260	260	10,0	17,5	24	118,4	●
WPB 260 x 260	172,42	290	268	18,0	32,5	24	219,6	●
WPB 280 x 280	61,25	264	280	7,0	10,0	24	78,0	●
WPB 280 x 280	76,35	270	280	8,0	13,0	24	97,3	●
WPB 280 x 280	103,00	280	280	10,5	18,0	24	240,2	●
WPB 280 x 280	188,53	310	288	18,5	33,0	24	361,9	●
WPB 300 x 300	69,79	283	300	7,5	10,5	27	88,9	●
WPB 300 x 300	88,33	290	300	8,5	14,0	27	112,5	●
WPB 300 x 300	117,03	300	300	11,0	19,0	27	149,1	●
WPB 300 x 300	237,92	340	310	21,0	39,0	27	303,1	●
WPB 320 x 300	74,24	301	300	8,0	11,0	27	94,6	●
WPB 320 x 300	97,63	310	300	9,0	15,5	27	124,4	●
WPB 320 x 300	126,65	320	300	11,5	20,5	27	161,3	●
WPB 320 x 300	244,96	359	309	21,0	40,0	27	312,0	●



IS WPB Parallel Flange Beams Wide Flange

Bahrain Rolling Mill ●
 Saudi Arabia Rolling Mill ●
 Subject to mill confirmation *

Designation	Mass kg/m	Dimensions					A cm ²	
		D Depth - mm	B width - mm	T web - mm	T flange - mm	R radius - mm		
WPB 340 x 300	78,89	320	300	8,5	11,5	27	100,5	●
WPB 340 x 300	104,78	330	300	9,5	16,5	27	133,5	●
WPB 340 x 300	134,15	340	300	12,0	21,5	27	170,9	●
WPB 340 x 300	247,92	377	309	21,0	40,0	27	315,8	●
WPB 360 x 300	83,69	339	300	9,0	12,0	27	106,6	●
WPB 360 x 300	112,06	350	300	10,0	17,5	27	142,8	●
WPB 360 x 300	141,80	360	300	12,5	22,5	27	180,6	●
WPB 360 x 300	250,26	395	308	21,0	40,0	27	318,8	●
WPB 400 x 300	92,39	378	300	9,5	13,0	27	117,7	●
WPB 400 x 300	124,80	390	300	11,0	19,0	27	159,0	●
WPB 400 x 300	155,26	400	300	13,5	24,0	27	197,8	●
WPB 400 x 300	255,74	432	307	21,0	40,0	27	325,8	●
WPB 450 x 300	99,74	425	300	10,0	13,5	27	127,1	●
WPB 450 x 300	139,75	440	300	11,5	21,0	27	178,0	●
WPB 450 x 300	171,11	450	300	14,0	26,0	27	218,0	●
WPB 450 x 300	263,32	478	307	21,0	40,0	27	335,4	●
WPB 500 x 300	107,45	472	300	10,5	14,0	27	136,9	●
WPB 500 x 300	155,07	490	300	12,0	23,0	27	197,5	●
WPB 500 x 300	187,33	500	300	14,5	28,0	27	238,6	●
WPB 500 x 300	270,27	524	306	21,0	40,0	27	344,3	●
WPB 550 x 300	119,98	522	300	11,5	15,0	27	152,8	●
WPB 550 x 300	166,23	540	300	12,5	24,0	27	211,8	●
WPB 550 x 300	199,44	550	300	15,0	29,0	27	254,1	●
WPB 550 x 300	278,19	572	306	21,0	40,0	27	354,4	●
WPB 600 x 300	128,79	571	300	12,0	15,5	27	164,1	●
WPB 600 x 300	177,77	590	300	13,0	25,0	27	226,5	●
WPB 600 x 300	211,92	600	300	15,5	30,0	27	270,0	●
WPB 600 x 300	285,47	620	305	21,0	40,0	27	363,7	●
WPB 650 x 300	137,97	620	300	12,5	16,0	27	175,8	●
WPB 650 x 300	189,69	640	300	13,5	26,0	27	241,6	●
WPB 650 x 300	224,78	650	300	16,0	31,0	27	286,3	●
WPB 650 x 300	293,38	668	305	21,0	40,0	27	373,7	●
WPB 700 x 300	149,89	670	300	13,0	17,0	27	190,9	●
WPB 700 x 300	204,48	690	300	14,5	27,0	27	260,5	●
WPB 700 x 300	240,51	700	300	17,0	32,0	27	306,4	●
WPB 700 x 300	300,67	716	304	21,0	40,0	27	383,0	●
WPB 800 x 300	171,51	770	300	14,0	18,0	30	218,5	●
WPB 800 x 300	224,37	790	300	15,0	28,0	30	285,8	●
WPB 800 x 300	262,33	800	300	17,5	33,0	30	334,2	●
WPB 800 x 300	317,35	814	303	21,0	40,0	30	404,3	●
WPB 900 x 300	198,00	870	300	15,0	20,0	30	252,2	●
WPB 900 x 300	251,61	890	300	16,0	30,0	30	320,5	●
WPB 900 x 300	291,45	900	300	18,5	35,0	30	371,3	●



JIS H-Beams

Dimensions, Masses, Tolerances and Surface Condition in accordance with JIS G 3192.

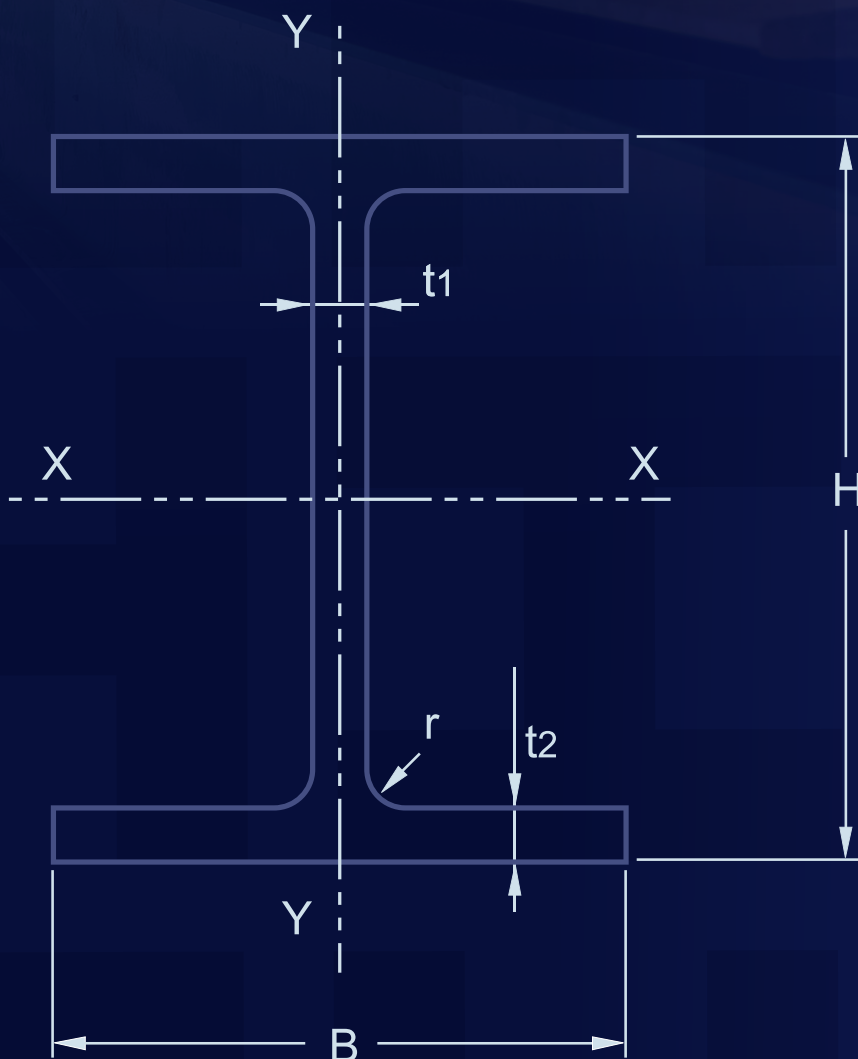



JIS H-Beams

Bahrain Rolling Mill ●
Saudi Arabia Rolling Mill ●
Subject to mill confirmation *

Designation	Mass kg/m	Dimensions				Area cm ²	
		H x B mm	t1 web mm	t2 flange mm	r radius mm		
100 x 50	9,30	100 x 50	5	7	8	11,85	●
100 x 100	16,9	100 x 100	6	8	8	21,59	●
150 x 150	31,1	150 x 150	7	10	8	39,65	●
175 x 175	40,4	175 x 175	7,5	11	13	51,42	●
200 x 100	17,8	198 x 99	4,5	7	8	22,69	●
	20,9	200 x 100	5,5	8	8	26,67	●
200 x 150	29,9	194 x 150	6	9	8	38,11	●
200 x 200	49,9	200 x 200	8	12	13	63,53	●
250 x 125	25,1	248 x 124	5	8	8	31,99	●
	29,0	250 x 125	6	9	8	36,97	●
250 x 175	43,6	244 x 175	7	11	13	55,49	●
250 x 250	63,8*	244 x 252	11	11	13	81,31	●
	71,8	250 x 250	9	14	13	91,43	●
	81,6 *	250 x 255	14	14	13	103,9	●
300 x 150	32,0	298 x 149	5,5	8	13	40,80	●
	36,7	300 x 150	6,5	9	13	46,78	●
300 x 200	55,8	294 x 200	8	12	13	71,05	●
	64,4	298 x 201	9	14	13	82,03	●
300 x 300	83,4 *	294 x 302	12	12	13	106,3	●
	93,0	300 x 300	10	15	13	118,5	●
	105 *	300 x 305	15	15	13	133,4	●
350 x 175	41,2	346 x 174	6	9	13	52,45	●
	49,4	350 x 175	7	11	13	62,91	●
350 x 250	78,1	340 x 250	9	14	13	99,53	●
350 x 350	135	350 x 350	12	19	13	171,9	●
400 x 200	56,1	396 x 199	7	11	13	71,41	●
	65,4	400 x 200	8	13	13	83,37	●
350 x 250	78,1	340 x 250	9	14	13	99,53	●
350 x 350	135	350 x 350	12	19	13	171,9	●
400 x 200	56,1	396 x 199	7	11	13	71,41	●
	65,4	400 x 200	8	13	13	83,37	●
400 x 300	105	390 x 300	10	16	13	133,2	●
400 x 400	172	400 x 400	13	21	22	218,7	●
	232	414 x 405	18	28	22	295,4	●
	283	428 x 407	20	35	22	360,7	●
450 x 200	65,1	446 x 199	8	12	13	82,97	●
	74,9	450 x 200	9	14	13	95,43	●
450 x 300	121	440 x 300	11	18	13	153,9	●
500 x 200	77,9	496 x 199	9	14	13	99,29	●
	88,2	500 x 200	10	16	13	112,2	●
500 x 300	111	482 x 300	11	15	13	141,2	●
	125	488 x 300	11	18	13	159,2	●
600 x 200	92,5 *	596 x 199	10	15	13	117,8	●
	103	600 x 200	11	17	13	131,7	●
600 x 300	133	582 x 300	12	17	13	169,2	●
	147	588 x 300	12	20	13	187,2	●
	170 *	594 x 302	14	23	13	217,1	●
700 x 300	163	692 x 300	13	20	18	207,5	●
	182	700 x 300	13	24	18	231,5	●
800 x 300	188 *	792 x 300	14	22	18	239,5	●
	207	800 x 300	14	26	18	263,5	●
900 x 300	210 *	890 x 299	15	23	18	266,9	●
	240	900 x 300	16	28	18	305,8	●
	283	912 x 302	18	34	18	360,1	●



KS H-Beams

Dimensions, Masses, Tolerances and Surface Condition in accordance with KS D 3502.

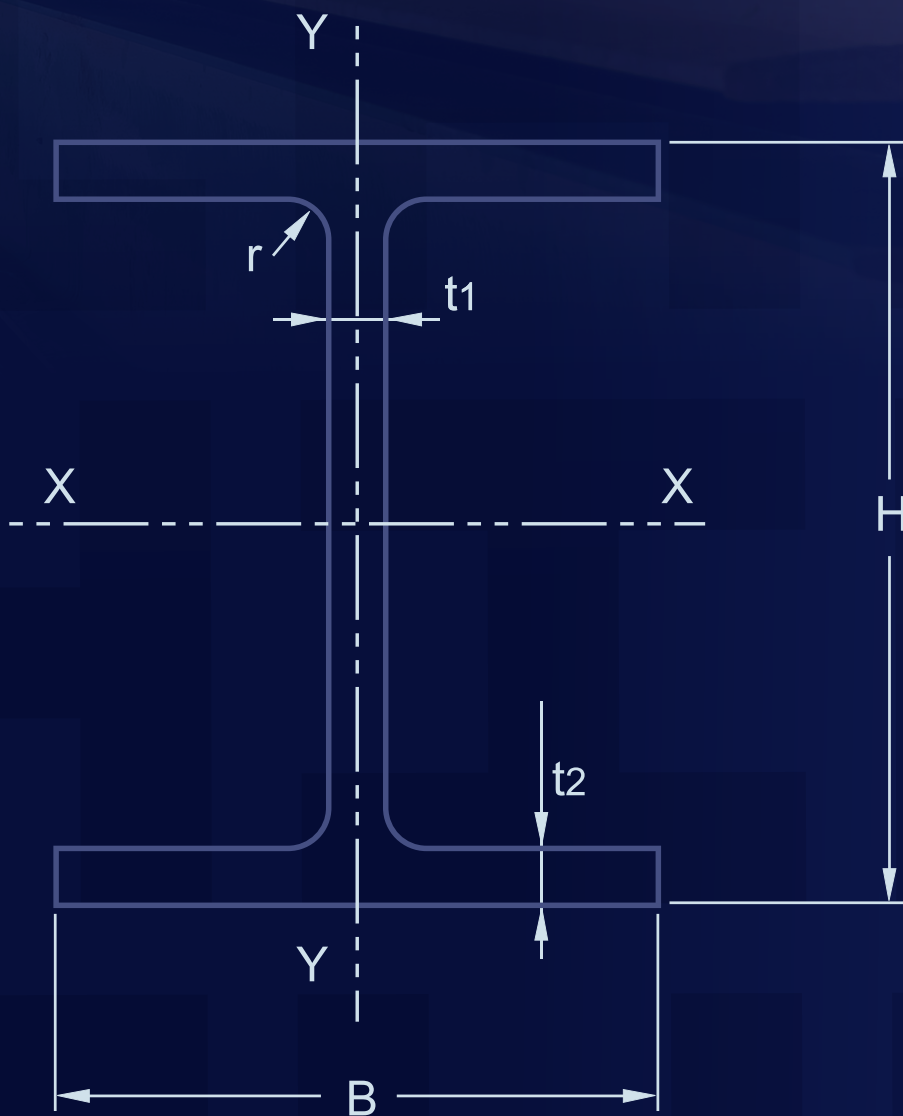



KS H-Beams

Bahrain Rolling Mill ●
Saudi Arabia Rolling Mill ●
Subject to mill confirmation *

Designation	Mass kg/m	Dimensions				Area cm ²	
		H x B mm	t1 web mm	t2 flange mm	r radius mm		
150 x 150	31,5	150 x 150	7	10	11	40,14	●
175 x 175	40,2 *	175 x 175	7,5	11	12	51,21	●
200 x 150	30,6	194 x 150	6	9	13	39,01	●
200 x 200	49,9	200 x 200	8	12	13	63,53	●
	56,2 *	200 x 204	12	12	13	71,53	●
	65,7 *	208 x 202	10	16	13	83,69	●
250 x 125	25,7	248 x 124	5	8	12	32,68	●
	29,6	250 x 125	6	9	12	37,66	●
250 x 175	44,1	244 x 175	7	11	16	56,24	●
250 x 250	64,4 *	244 x 252	11	11	16	82,06	●
	66,5 *	248 x 249	8	13	16	84,70	●
	72,4	250 x 250	9	14	16	92,18	●
	82,2 *	250 x 255	14	14	16	104,7	●
300 x 150	32,0 *	298 x 149	5,5	8	13	40,80	●
	36,7	300 x 150	6,5	9	13	46,78	●
300 x 200	56,8	294 x 200	8	12	18	72,38	●
	65,4	298 x 201	9	14	18	83,36	●
300 x 300	84,5 *	294 x 302	12	12	18	107,7	●
	87,0 *	298 x 299	9	14	18	110,8	●
	94,0	300 x 300	10	15	18	119,8	●
	106,0 *	300 x 305	15	15	18	134,8	●
	106,0 *	304 x 301	11	17	18	134,8	●
	130,0 *	310 x 305	15	20	18	165,3	●
	142,0 *	310 x 310	20	20	18	180,8	●
350 x 175	41,4 *	346 x 174	6	9	14	52,68	●
	49,6	350 x 175	7	11	14	63,14	●
	57,8 *	354 x 176	8	13	14	73,68	●
350 x 250	69,2 *	336 x 249	8	12	20	88,15	●
	79,7 *	340 x 250	9	14	20	101,5	●
350 x 350	106,0 *	338 x 351	13	13	20	135,3	●
	115,0 *	344 x 348	10	16	20	146,0	●
	131,0 *	344 x 354	16	16	20	166,6	●
	137,0	350 x 350	12	19	20	173,9	●
	156,0 *	350 x 357	19	19	20	198,4	●
400 x 200	56,6 *	396 x 199	7	11	16	72,16	●
	66,0	400 x 200	8	13	16	84,12	●
400 x 300	107,0 *	390 x 300	10	16	22	136,0	●
400 x 400	140,0 *	388 x 402	15	15	22	178,5	●
	147,0 *	394 x 398	11	18	22	186,8	●
	168,0 *	394 x 405	18	18	22	214,4	●
	172,0	400 x 400	13	21	22	218,7	●
	197,0 *	400 x 408	21	21	22	250,7	●
	200,0 *	406 x 403	16	24	22	254,9	●
	232,0	414 x 405	18	28	22	295,4	●
	283,0	428 x 407	20	35	22	360,7	●
450 x 200	66,2 *	446 x 199	8	12	18	84,30	●
	76,0	450 x 200	9	14	18	96,76	●
450 x 300	106,0 *	434 x 299	10	15	24	135,0	●
	124,0 *	440 x 300	11	18	24	157,4	●



KS H-Beams

Bahrain Rolling Mill ●
Saudi Arabia Rolling Mill ●
Subject to mill confirmation *

Designation	Mass kg/m	Dimensions				Area cm ²	
		H x B mm	t1 web mm	t2 flange mm	r radius mm		
500 × 200	79,5 *	496 × 199	9	14	20	101,3	●
	89,6	500 × 200	10	16	20	114,2	●
	103,0 *	506 × 201	11	19	20	131,3	●
500 × 300	114,0	482 × 300	11	15	26	145,5	●
	128,0	488 × 300	11	18	26	163,5	●
600 × 200	94,6 *	596 × 199	10	15	22	120,5	●
	106,0	600 × 200	11	17	22	134,4	●
	120,0 *	606 × 201	12	20	22	152,5	●
	134,0 *	612 × 202	13	23	22	170,7	●
600 × 300	137,0	582 × 300	12	17	28	174,5	●
	151,0	588 × 300	12	20	28	192,5	●
	175,0	594 × 302	14	23	28	222,4	●
700 × 300	166,0	692 × 300	13	20	28	211,5	●
	185,0	700 × 300	13	24	28	235,5	●
	215,0 *	708 × 302	15	28	28	273,6	●
800 × 300	191,0 *	792 × 300	14	22	28	243,4	●
	210,0	800 × 300	14	26	28	267,4	●
	241,0 *	808 × 302	16	30	28	307,6	●
900 × 300	213,0 *	890 × 299	15	23	28	270,9	●
	243,0	900 × 300	16	28	28	309,8	●
	286,0 *	912 × 302	18	34	28	364,0	●
	307,0 *	918 × 303	19	37	28	391,3	●



H-PILES

ASTM (AMERICAN)

- HP Shapes (HP)

EN (EUROPEAN)

- Wide Flange Bearing Piles (HP)
- Universal Bearing Piles (UBP)

KS (KOREAN)

- H Piles





ASTM HP Shapes

HP shapes in accordance with ASTM A6/A6M

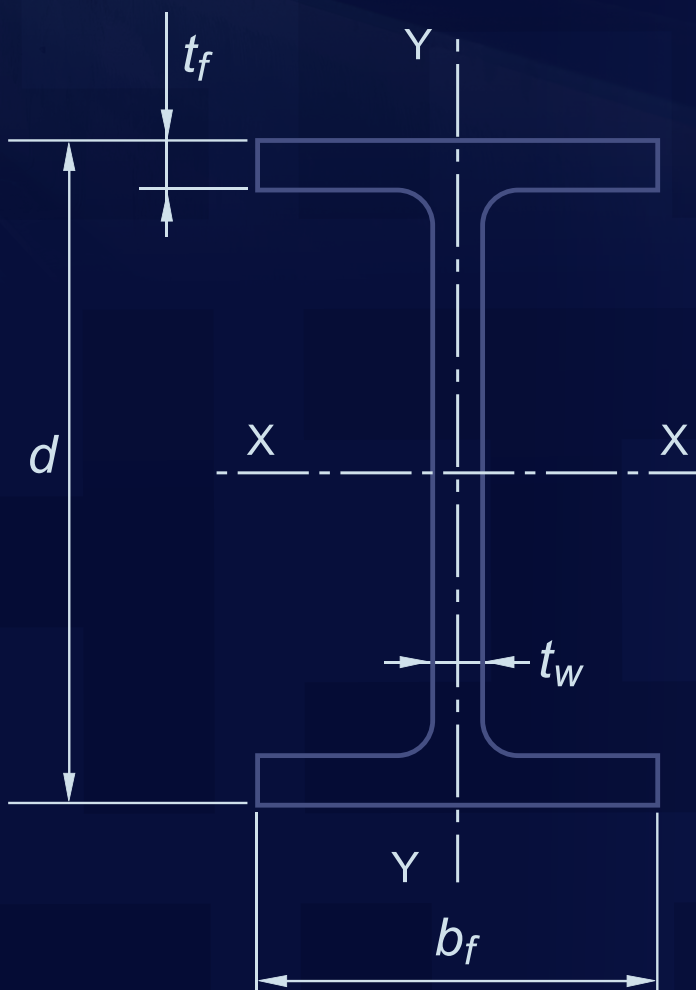



ASTM HP Shapes

ASTM A6 Standard Section Dimensions (Imperial)					
HP Shape Designation <small>(Nominal Depth in Inches and Weight in Pounds per Linear Foot)</small>	Area A in ²	Depth d in.	Flange		Web Thickness t _w in.
			Width	Thickness	
			b _f in.	t _f in.	
HP 14x14 (Imperial)					
HP 14x73	21.4	13.61	14.585	0.505	0.505
HP 14x89	26.1	13.83	14.695	0.615	0.615
HP 14x102	30.0	14.01	14.785	0.705	0.705
HP 14x117	34.4	14.21	14.885	0.805	0.805

ASTM A6M Standard Section Dimensions (Metric)					
HP Shape Designation <small>(Nominal Depth in Millimetres and Mass in Kilograms per Metre)</small>	Area A mm ²	Depth d mm	Flange		Web Thickness t _w mm
			Width	Thickness	
			b _f mm	t _f mm	
HP 360x360 (Metric)					
HP 360x108	13,800	346	370	12.8	12.8
HP 360x132	16,800	351	373	15.6	15.6
HP 360x152	19,400	356	376	17.9	17.9
HP 360x174	22,200	361	378	20.4	20.4



EN Wide Flange Bearing Piles (HP)

Dimensions and Masses in accordance with EN 10365. Tolerances in accordance with EN 10034. Surface Condition in accordance with EN 10163-3, class C, subclass 1.

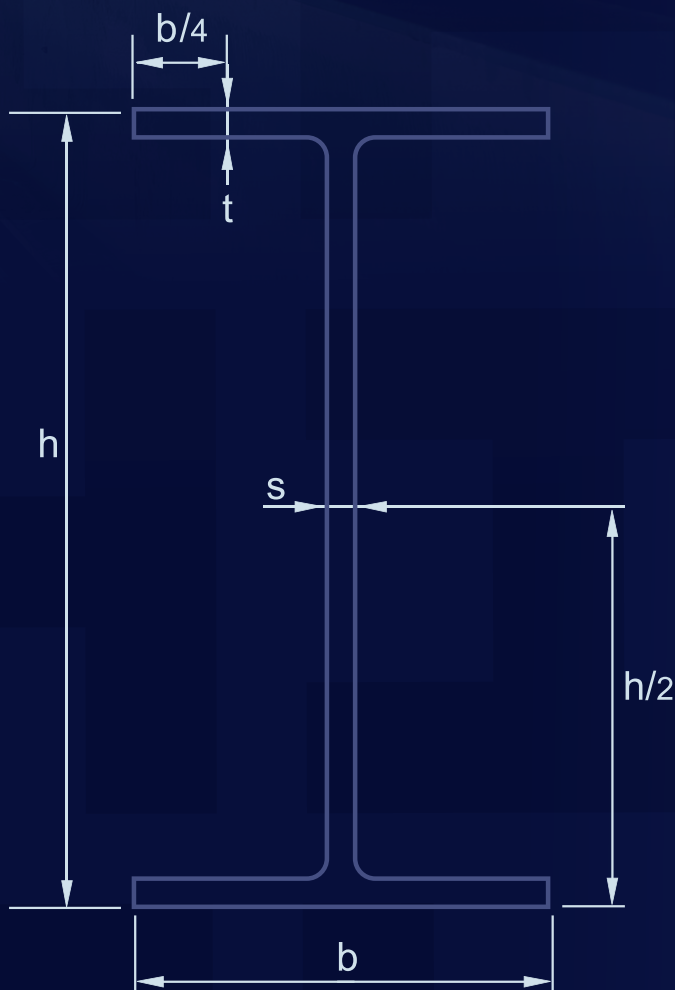



EN Wide Flange Bearing Piles (HP)

Bahrain Rolling Mill ●
Saudi Arabia Rolling Mill ●

Designation	G kg/m	Dimensions				A cm ²	
		h mm	b mm	s mm	t mm		
HP 305 x 149	149	318,5	316,0	20,6	20,7	189,9	●
HP 305 x 180	180	326,7	319,7	24,8	24,8	229,3	●
HP 305 x 223	223	337,9	325,7	30,3	30,4	284,0	●
HP 360 x 109	109	346,4	371,0	12,8	12,9	138,7	●
HP 360 x 133	133	352,0	373,8	15,6	15,7	169,4	●
HP 360 x 152	152	356,4	376,0	17,8	17,9	193,7	●
HP 360 x 174	174	361,4	378,5	20,3	20,4	221,5	●



EN Universal Bearing Piles (UBP)

Dimensions and Masses in accordance with EN 10365. Tolerances in accordance with EN 10034. Surface Condition in accordance with EN 10163-3, class C, subclass 1.

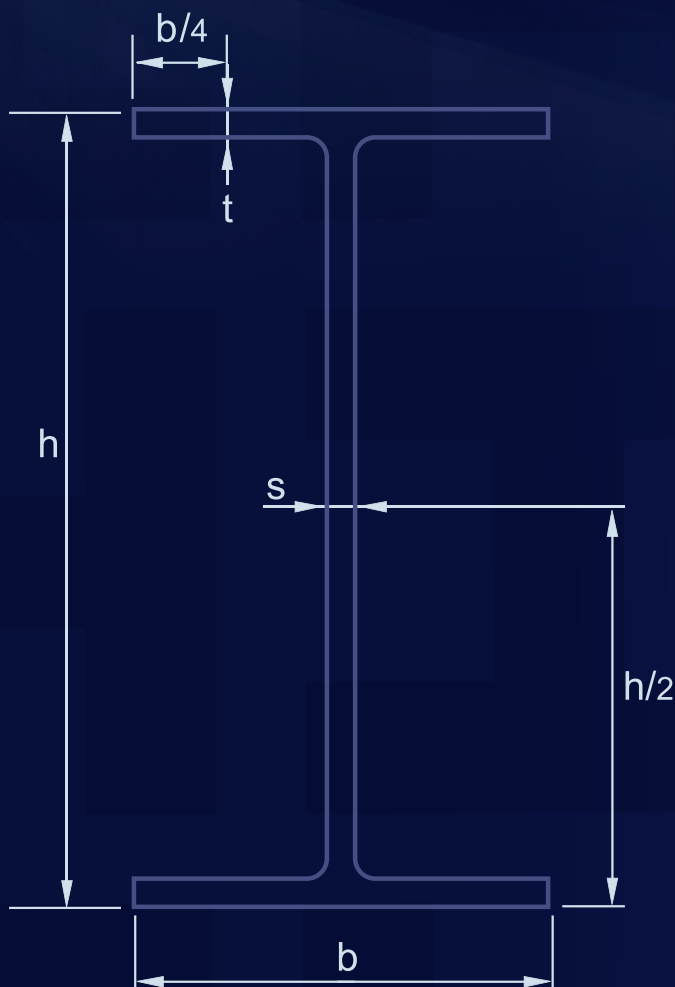



EN Universal Bearing Piles (UBP)

Bahrain Rolling Mill ●
Saudi Arabia Rolling Mill ●

Designation	G kg/m	Dimensions				A cm ²	
		h mm	b mm	s mm	t mm		
UBP 356 x 368 x 109	109	346,4	371,0	12,8	12,9	138,7	●
UBP 356 x 368 x 133	133	352,0	373,8	15,6	15,7	169,4	●
UBP 356 x 368 x 152	152	356,4	376,0	17,8	17,9	193,7	●
UBP 356 x 368 x 174	174	361,4	378,5	20,3	20,4	221,5	●



KS H-Piles

Dimensions, Masses, Tolerances and Surface Condition in accordance with KS F 4603.

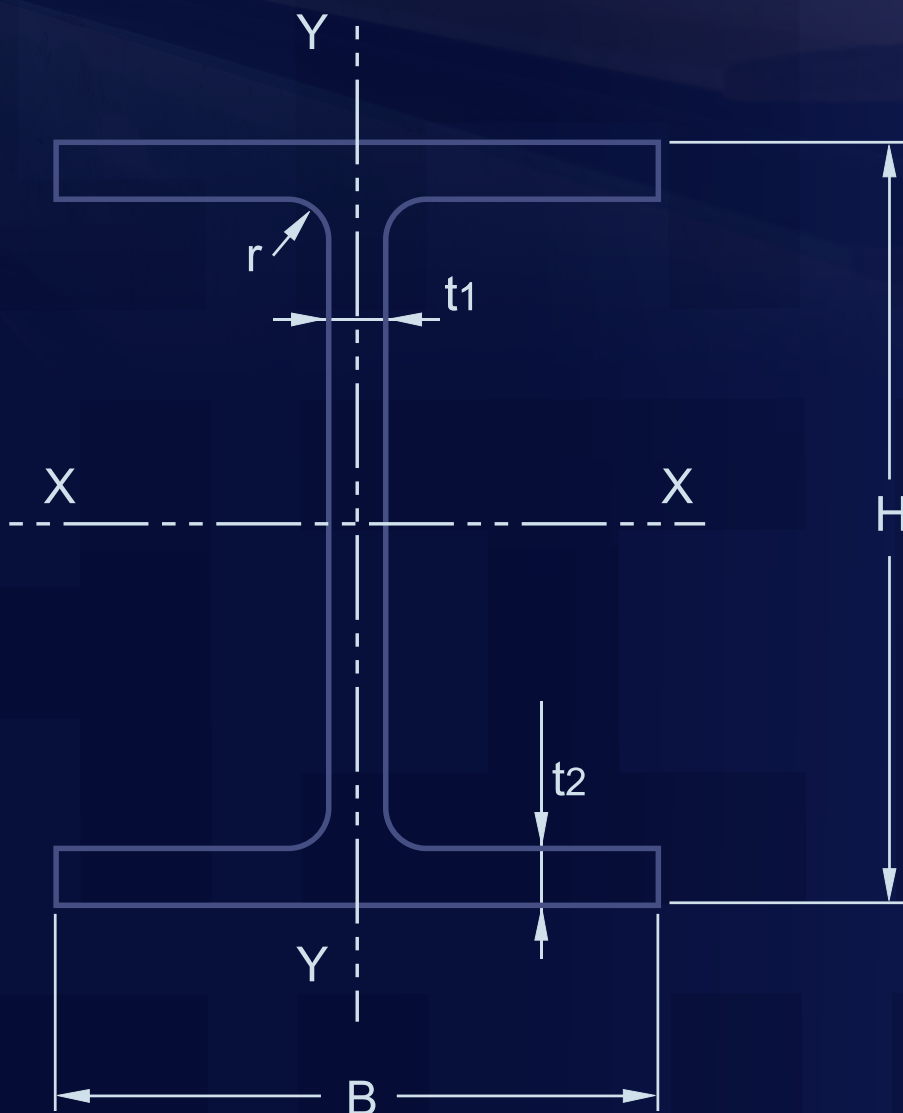



KS H-Piles

Bahrain Rolling Mill ●
Saudi Arabia Rolling Mill ●
Subject to mill confirmation *

Designation	Mass kg/m	Dimensions				Area cm ²	
		H x B mm	t1 web mm	t2 flange mm	r radius mm		
200 × 200	49,9	200 × 200	8	12	13	63,53	●
	56,2 *	200 × 204	12	12	13	71,53	●
	65,7 *	208 × 202	10	16	13	83,69	●
250 × 250	64,4 *	244 × 252	11	11	16	82,06	●
	66,5 *	248 × 249	8	13	16	84,70	●
	72,4	250 × 250	9	14	16	92,18	●
	82,2 *	250 × 255	14	14	16	104,7	●
300 × 200	56,8	294 × 200	8	12	18	72,38	●
	65,4	298 × 201	9	14	18	83,36	●
300 × 300	84,5 *	294 × 302	12	12	18	107,7	●
	87,0 *	298 × 299	9	14	18	110,8	●
	94,0	300 × 300	10	15	18	119,8	●
	106,0 *	300 × 305	15	15	18	134,8	●
	106,0 *	304 × 301	11	17	18	134,8	●
	130,0 *	310 × 305	15	20	18	165,3	●
	142,0 *	310 × 310	20	20	18	180,8	●
350 × 350	106,0 *	338 × 351	13	13	20	135,3	●
	115,0 *	344 × 348	10	16	20	146,0	●
	131,0 *	344 × 354	16	16	20	166,6	●
	137,0	350 × 350	12	19	20	173,9	●
	156,0 *	350 × 357	19	19	20	198,4	●
400 × 400	140,0 *	388 × 402	15	15	22	178,5	●
	147,0 *	394 × 398	11	18	22	186,8	●
	168,0 *	394 × 405	18	18	22	214,4	●
	172,0	400 × 400	13	21	22	218,7	●
	197,0 *	400 × 408	21	21	22	250,7	●
	200,0 *	406 × 403	16	24	22	254,9	●
	232,0	414 × 405	18	28	22	295,4	●
	283,0	428 × 407	20	35	22	360,7	●



GENERAL ENQUIRIES

P.O. Box 50177
Hidd, Kingdom of
Bahrain

 +973 17 352 406
 info@sulb.com
 www.sulb.com



BAHRAIN OFFICE



 +973 17 352 415
 sales@sulb.com.bh



SAUDI ARABIA OFFICE

 +966 13 358 6666
 sales@sulbsaudi.com.sa

UAE OFFICE

 +971 4 5587 235/239
 sales@sulb.com.bh

